

**COUNTY OF BERKS**

**Invitation to Bid #24-08-GR**

**for**

**Wertz Covered Bridge Stair Replacement Project**

**Issued on March 19, 2024**

**Pre-Bid Conference:**

**Wednesday, April 3, 2024, 10:00 A.M., Local Prevailing Time  
Refer to Section One, Paragraph #1.C for details.**

**Submittal Deadline:**

**Thursday, May 2, 2024, 2:00 P.M., Local Prevailing Time  
Refer to Section One, paragraph 4 for submittal instructions.**

**Opening Date/Time:**

**Thursday, May 2, 2024, 2:15 P.M., Local Prevailing Time**

**County's Point-of-Contact for this ITB:**

**George M. Rodrigues**

**Tel: 610-478-6168 Fax: 610-898-7404**

**Email: grodrigues@berkspa.gov**

**Mailing Address: Purchasing Department, 13<sup>th</sup> Floor, Berks County Services Center,  
633 Court Street, Reading, PA, 19601**

**Engineer for this Project is:**

**Great Valley Consultants**

**Terrance R. Naugle, R.A.**

**Tel: 610-375-8822**

**Email: tnaugle@greatvalleyconsultants.com**

This Invitation to Bid (ITB) package consists of 154 pages including this cover page and the Table of Contents page. If the ITB package you received is missing any pages, contact the County of Berks Purchasing Department at telephone number (610) 478-6168.

## TABLE OF CONTENTS

---

1. INSTRUCTIONS TO BIDDERS AND GENERAL CONDITIONS OF CONTRACT
2. ADVERTISEMENT FOR BIDS
3. TECHNICAL SPECIFICATIONS
4. FORM OF BID BOND
5. FORM OF PERFORMANCE BOND
6. FORM OF PAYMENT BOND
7. CONTRACT
8. BID FORM
9. SUBCONTRACTORS LIST
10. EQUIPMENT SUPPLIERS LIST
11. ALTERNATES/SUBSTITUTION LIST
12. NON-COLLUSION AFFIDAVIT
13. AGREEMENT OF SURETY
14. LIST OF STATUTES
15. APPENDIX A – CONSTRUCTION PLANS
16. APPENDIX B – PREVAILING WAGE RATES
17. APPENDIX C - ACT NO. 45-1998 (72 P.S. § 7201 ET SEQ.)
18. APPENDIX D – WORKER PROTECTION AND INVESTMENT CERTIFICATION FORM BOP-2201
19. APPENDIX E - HOW TO JOIN AND PARTICIPATE IN A MICROSOFT TEAMS MEETING

**SECTION ONE**  
**INSTRUCTIONS TO BIDDERS AND GENERAL CONDITIONS OF CONTRACT**

---

**1. BID DOCUMENT AVAILABILITY & PRE BID**

A. The Bid Documents have been prepared by and may be obtained from the County of Berks. The Bid Documents are made available only for the purpose of obtaining Bids for this Project. Their availability does not grant a license for other purposes.

B. Upon receipt of Bid Documents, Bidders shall verify that the documents are complete. Bidder shall notify the County of Berks should the documents be incomplete, or upon finding discrepancies or omissions in the Bid Documents. Bidder shall be responsible for the completeness of their set of Bid Documents. No allowance or concession will be made to a Bidder who complains of missing portions of Bid Documents subsequent to the award of Bid. All requests for clarifications must be in writing and received by the County of Berks no less than seven (7) days before Bid deadline. All clarifications, modifications and corrections to the Bid Documents shall be issued in the form of Addenda and shall be forwarded to all known Bidders. Addenda listing revisions and changes to the Bid Documents shall become a part of and take precedence over original Bid Documents and shall be so honored by Bidders in preparing their Bids.

C. A pre-bid meeting will be held at the Wertz Covered Bridge (“Bridge”) located at the Red Bridge Recreation Area at 2141 Tulpehocken Road, Wyomissing, PA 19610 on Wednesday, April 3, 2024, beginning promptly at 10:00 A.M.

D. The purpose of this meeting is to conduct a question and answer session regarding this ITB package to maximize the Bidders’ understanding of the requirements of this ITB and to conduct a site tour to allow Bidders to become familiar with the general, local, and site conditions that may affect cost, progress, performance, or furnishing of the Work, to the extent that the information is reasonably obtainable. In no event shall failure to inspect the site relieve the Bidder from the consequences of such failure and shall not constitute grounds for a claim after contract award. A list of those companies represented at the pre-bid meeting will be recorded

**2. DEFINITIONS**

A. Bid Documents: Advertisement for Bids, Instructions to Bidders and General Conditions of Contract, Bid Bond, Performance Bond, Payment Bond, Non-Collusion Affidavit, Worker Protection and Investment Certification Form, Subcontractors List, Equipment Suppliers List, Alternates/Substitution List, List of Statutes, Specifications, Plans (if applicable), Bid Form and any Addenda.

B. Bidder: Person or entity submitting a Bid.

C. Bid Sum: Monetary sum identified by Bidder in Bid Form.

D. Contract: Bid Documents and Contract. The terms “Contract” and “Contract Documents” are used interchangeably.

**SECTION ONE**  
**INSTRUCTIONS TO BIDDERS AND GENERAL CONDITIONS OF CONTRACT**

---

- E. Contractor: Successful Bidder, i.e., Bidder to whom Contract is awarded.
- F. Project: Wertz Covered Bridge Stair Replacement.
- G. County: County of Berks, its agents, employees and/or authorized representative.

**3. APPLICABILITY OF INSTRUCTIONS AND CONDITIONS**

These Instructions to Bidders and General Conditions of Contract are a standardized listing of items generally applicable to Bids for contracted services, specific projects, annual maintenance and other annual contracts entered into by the County. Where an item applies in limited cases, the same shall be noted as well as the conditions respecting applicability. If a Bidder is unsure as to the applicability of a particular item, the County should be contacted for clarification.

**4. PREPARATION AND SUBMISSION OF BIDS**

A. Bidder shall be solely responsible for the delivery of its Bids in the manner and time prescribed. All Bids must be received by the County at the place designated in the Advertisement for Bids, prior to the time designated in the Advertisement for Bids for Bid opening. Bids received after the time advertised for Bid opening shall be returned to Bidders unopened.

B. Bids shall be prepared and submitted on forms furnished by the County. All blank spaces shall be filled in, by typewriter or ink, and amounts shown in both words and numbers. In case of discrepancy, the written words shall be considered as being the Bid Sum. All prices are to be firm net prices and are to be F.O.B. destination, including, without limitation, charges for delivery, transportation, placement, handling charges, labor, overhead, profit, etc.

C. All Bids shall be irrevocable for a period of sixty (60) days from Bid opening or a longer time if required elsewhere in the Bid Documents or by law. County shall be permitted to order increased quantities of any item Bid, over and above those specified, at the Bid Sum included in the Bid during said sixty (60) day period.

D. The Bid Form shall be signed in accordance with the following:

(1) If the Bidder is an individual, the Bid shall be executed by him, personally; his signature shall be witnessed; his business address shall be stated, and any trade name employed in the conduct of his business shall be stated.

(2) If the Bidder is a partnership, the Bid Form shall be executed in the name of the partnership by each of the partners, or a general partner authorized for this purpose; the signatures of the partners shall be witnessed; the business of the partnership shall be stated; and the business address of the partnership shall be stated.

**SECTION ONE**  
**INSTRUCTIONS TO BIDDERS AND GENERAL CONDITIONS OF CONTRACT**

---

(3) If the Bidder is a corporation, the Bid Form shall be executed in its name and on its behalf: (a) by the President or Vice President and attested by the Secretary or Assistant Secretary, and the Corporate Seal shall be affixed; or (b) by a duly authorized agent of the corporation whose authority to act, as of the date of the Bid, shall be established by a certified copy of a resolution by the Board of Directors of the bidding corporation authorizing said agent to sign the Bid on behalf of the corporation, submitted with the Bid. The business address of the corporation and state of incorporation shall be stated.

(4) If the Bidder is a joint venture, each party of the joint venture shall execute the Bid Form under their respective seals in a manner appropriate to such party as described above.

E. Bids exceeding Five Thousand Dollars (\$5,000.00) shall be accompanied by Bid Security in the form of a Bid Bond prepared on the form contained in the Bid Documents. The Bid Bond shall be accompanied with a power of attorney evidencing the authority of the agent of the surety to execute the bond as of the date of the Bid. The Bid Bond form must be executed by a surety named in the current list of "Companies Holding Certificates of Authority as Acceptable Sureties on Federal Bonds and as Acceptable Reinsuring Companies," as published in Circular 570 (as amended) by the Audit Staff, Bureau of Government Financial Operations, U.S. Treasury Department, and the amount of the bond shall not exceed the underwriting risk of such surety as set forth in said circular or revision thereof. The surety shall be licensed and qualified to do business in the Commonwealth of Pennsylvania. The Bid Bond shall name as payee or obligee, as appropriate, the County, and shall be in an amount not less than Ten Percent (10%) of the Bid Sum. Bid Bonds will be returned upon Bidder's request on or after sixty (60) calendar days following the opening of Bids. Bid Bonds accompanying the lowest proposal will be returned upon submission and approval of the required Payment Bond and Performance Bond by the successful Bidder to the County.

F. As a precondition of the award of the Contract, the Bid shall be accompanied by a completed Verification Form required by the Public Works Employment Verification Act, Act No. 127, July 5, 2012 (formerly Senate Bill 637) acknowledging the Bidder's responsibilities and compliance with the Public Works Employment Verification Act. The Verification Form shall be obtained from the Secretary of the Pennsylvania Department of General Services and shall include a certification that the information is true and correct, subject to sanctions provided by law. The Verification Form shall be executed by a representative who has sufficient knowledge and authority to make the representations and certifications contained in the Verification Form. If awarded the Contract, Bidder shall cause each Subcontractor (as defined in the Public Works Employment Verification Act) to submit to the Owner a separate and complete Verification Form, executed by a representative who has sufficient knowledge and authority to make the representations and certifications contained in the Verification Form, as required by the Public Works Employment Verification Act, Act No. 127, July 5, 2012 (formerly Senate Bill 637), for before performing any Work on the Project.

**SECTION ONE**  
**INSTRUCTIONS TO BIDDERS AND GENERAL CONDITIONS OF CONTRACT**

---

G. To ensure compliance with all applicable Pennsylvania state labor and workforce safety laws, the Bid shall be accompanied by a completed Worker Protection and Investment Certification Form BOP-2201 acknowledging the Bidder's responsibilities and compliance with Executive Order 2021-06, Worker Protection and Investment, October 21, 2021. Refer to Appendix "D" for the Worker Protection and Investment Certification Form BOP-2201. The Worker Protection and Investment Certification Form BOP-2201 shall be executed by a representative who has sufficient knowledge and authority to make the representations and certifications contained in the Form.

H. All Bids, including required enclosures if applicable, shall be submitted in a sealed opaque envelope, clearly identified with Bidder's name and the name of the Project subject to the Bid. The envelope should also contain a notation that it should not be opened until the time specified for Bid opening. Bid envelopes not bearing this notation and opened in error may be rejected by the County, in its sole discretion. If a Bidder elects to submit a Bid by mailing rather than hand delivery, the sealed Bid envelope described above shall be enclosed in a mailing envelope and addressed to the County, and must be received prior to the date and time specified for Bid opening.

**5. STANDARD OF QUALITY**

A. The various materials and products specified in the Specifications by name or description are given to establish a standard of the quality and of cost for Bid purposes. It is not the intent to limit the Bidder, the Bid or the evaluation of the Bid to any one material or product specified but rather to describe the minimum standard. When proprietary names are used, they shall be deemed to be followed by the words "or alternatives of the quality necessary to meet the specifications." A Bid containing an alternative which does not meet the Specifications may be declared non-responsive. A Bid containing an alternative may be accepted but, if an award is made to that Bidder, the Bidder will be required to replace any alternatives which do not meet the Specifications.

B. No substitution (alternative) will be considered prior to receipt of Bids unless written request for approval has been received by the County at least ten (10) days prior to the date for receipt of Bids. Such requests shall include, but not be limited to, the name of the material or equipment for which it is to be substituted and a complete description of the proposed substitution including, without limitation, technical information, specifications, manufacturer's name and catalog number, drawings, performance and test data, and other information necessary for an evaluation. Bidder shall provide samples if requested. A descriptive catalog must accompany the Bid.

C. If the County approves a proposed substitution (alternative) prior to receipt of Bids, such approval will be set forth in an Amendment. Bidders shall not rely upon approvals in any other manner.

**SECTION ONE**  
**INSTRUCTIONS TO BIDDERS AND GENERAL CONDITIONS OF CONTRACT**

---

D. Substitutions (alternatives) may be submitted as part of a Bid only if the Bidder includes all information required under paragraph B. above for each substitution (alternative) submitted as part of the Bid and clearly indicates the request for substitution (alternative) on the form of proposal. The County shall not be required to consider or accept any substitution (alternative) that is not specifically identified in a written request for substitution included with the Bid submittal. Failure of the successful Bidder to specifically identify a substitution (alternative) in a request for substitution included with its Bid submittal shall result in the successful Bidder being required to complete the work using materials and products named in the Specifications.

E. The County shall be the sole judge in making a determination as to quality and the County shall have the sole and absolute discretion to decide whether to accept any substitution (alternative) in a request for substitution. If the Bidder submits no written request for substitution with the Bid submittal, it is understood that the Bidder will supply the specific item named in the Specifications.

**6. MODIFICATION AND WITHDRAWAL**

A. Bids may not be modified after submittal.

B. Bids may be withdrawn after submittal, provided Bidder makes his request to withdraw in writing and the request is received prior to the time specified for Bid opening.

C. Negligence by Bidder in preparing his Bid confers no right of withdrawal or modification of his Bid after such Bid has been opened. No claims on account of mistakes or omissions in any Bid will be considered. Notwithstanding the above, a Bidder may withdraw his Bid after such Bid has been opened in accordance with the causes set forth in the Pennsylvania Bid Withdrawal Act, Act No. 4 of 1974, 73 P.S. §1601 et seq. Strict compliance with said Act is required to withdraw a Bid after Bid opening.

**7. OPENING OF BIDS**

Bids will be publicly opened at 2:15 P.M., local prevailing time, on Thursday, May 2, 2024 (“Bid Opening”), through a Microsoft Teams meeting. A summary of bids received (company name and Bid price) will be posted on the Purchasing Department page of the County’s website ([www.berkspa.gov](http://www.berkspa.gov)). The public may participate in the opening of this invitation to bid through the URL shown below.

The Microsoft Teams URL for the opening can be located at the following site under the listing for this specific ITB: <https://www.berkspa.gov/departments/purchasing/itb-rfp>.

Refer to Appendix E for detailed instructions on how to participate in the opening through a Microsoft Teams meeting.

**SECTION ONE**  
**INSTRUCTIONS TO BIDDERS AND GENERAL CONDITIONS OF CONTRACT**

---

**8. QUALIFICATIONS**

Prior to the award of Contract, County may require satisfactory evidence to show that the Bidder is fully prepared in every way to perform the Contract timely and that he has been regularly engaged in such business.

**9. COLLUSIVE BIDS**

More than one Bid for one Contract from an individual, partnership, corporation, or an association under the same or different names will be grounds for rejection of all Bids in which such Bidder is interested. Any and all Bids will be rejected if there is any reason for believing that collusion exists among any of the Bidders. Participants in such collusion will not be considered in future Bids.

**10. BID INELIGIBILITY**

A. Failure to provide Bid Security shall result in rejection of Bid.

B. Bids not based on Bid Documents, those indicating a qualification of the Bid, conditions or uninvited alternate Bids, or which contain alteration of Bid Forms, may be rejected by the County in its sole and absolute discretion. In addition, Bids failing to adhere to the Specifications as provided in Exhibit "A" attached to the Contract may be rejected by the County in its sole and absolute discretion.

C. Bids that are unsigned, improperly signed or sealed, or illegible, may be rejected by the County in its sole and absolute discretion.

D. Bids where the prices are obviously unbalanced may be rejected by the County in its sole and absolute discretion.

E. Bids containing "escalator" clauses may be rejected by the County at the County's sole and absolute discretion.

F. All Bids shall conform with these Instructions to Bidders and General Conditions of Contract. Bids containing minor irregularities or informalities, not relating to price, time, or changes in the work to be performed pursuant to the Contract, may be rejected at the County's sole and absolute discretion. The County reserves the right to waive any such informalities or irregularities when a waiver is in the County's best interest.



**SECTION ONE**  
**INSTRUCTIONS TO BIDDERS AND GENERAL CONDITIONS OF CONTRACT**

---

**11. BID REJECTION OR AWARD**

The County reserves the right to reject any and all Bids, or parts of a Bid, when a rejection is in the County's best interest. The County reserves the right to reject a Bid if the Bidder is not in a position to perform the Contract or has previously failed to perform similar contracts properly or on time as determined by the County in its sole discretion. If a Contract is awarded, it will be to the lowest responsible Bidder, provided such Bidder's Bid is reasonable and in the County's interest to accept.

In the event of a dispute between a Bidder and the County regarding the County's determination of which Bidder is the lowest responsive, responsible Bidder, such contesting Bidder shall be responsible for any legal fees (e.g., fees of attorneys, paralegals and other legal professionals), professional fees, or other costs or expenses incurred by the County. The contesting Bidder shall pay such legal fees, professional fees, or other costs or expenses within seven (7) days of receipt of the County's invoice. Furthermore, under no circumstances shall the County be responsible for any legal fees, professional fees, or other costs or expenses incurred by the contesting Bidder if the County decides not to award the Contract to such Bidder based upon the County's determination in its sole and absolute discretion that such contesting Bidder is not the lowest responsive, responsible Bidder.

**12. CONTRACT**

A. Every Contract shall be awarded by the County to the lowest responsible Bidder within sixty (60) calendar days of the date of Bid opening unless this time is extended by the mutual consent of the Bidder and the County.

B. The County reserves the right to award a Contract for one or more of the items set forth in the Specifications, or for all items set forth in the Specifications.

C. A Contract shall be awarded and shall become binding upon the Bidder and the County pursuant to the issuance of a Contract by the County covering any or all items included in the Bid.

D. The Contract Documents consist of the Contract and the Bid Documents.

**13. PAYMENT AND PERFORMANCE BONDS**

A. In accordance with the Public Works Contractors' Bond Law of 1967, Act of Dec. 20, 1967, P.L. 869, No. 385 any Contract for construction, reconstruction, alteration or repair of any public building or other public work in an amount exceeding Five Thousand Dollars (\$5,000.00) the Contractor shall furnish to County the following bonds, which shall be binding upon the award of said Contract to such Contractor:

**SECTION ONE**  
**INSTRUCTIONS TO BIDDERS AND GENERAL CONDITIONS OF CONTRACT**

---

(1) A performance bond in the amount of One Hundred Percent (100%) of the contract sum, conditioned upon the faithful performance of the Contract in accordance with the Contract Documents shall be submitted. Such bond shall be executed on the form contained in the Bid Documents and shall be solely for the protection of County.

(2) A payment bond in the amount of One Hundred Percent (100%) of the contract sum, shall be submitted. Such bond shall be executed on the form contained in the Bid Documents and shall be solely for the protection of claimants supplying labor and materials to the Contractor, or to any of the Contractor's subcontractors, in the prosecution of the work provided for in such Contract, and shall be conditioned upon the prompt delivery of such materials furnished or labor supplied or performed in the prosecution of the work.

B. Each of the above-referenced bonds shall be executed by a surety named in the current list of "Companies Holding Certificates of Authority as Acceptable Sureties on Federal Bonds and as Acceptable Reinsuring Companies," as published in Circular 570 (as amended) by the Audit Staff, Bureau of Governmental Financial Operations, U. S. Treasury Department, and the amount of the bonds shall not exceed the underwriting risk of the surety as set forth in said circular or revision thereof. The surety shall be licensed and qualified to do business in the Commonwealth of Pennsylvania. The bonds shall be accompanied by a power of attorney evidencing the authority of the agent of the surety to execute the bonds as of the date of the bonds.

C. Failure of a Contractor to submit the required bonds within ten (10) calendar days of the date of the County's Contract shall constitute a default by the Contractor, and the County may, at its sole discretion, award the Contract to the next lowest responsible Bidder, reserving to itself all rights for damages relating to said default, or, in the alternative, allow the Contractor additional time in which to secure the required bonds. Other forms of bonds or changes in amounts may be required in the Specifications.

**14. DETAILED COST BREAKDOWN**

For any Contract exceeding Five Thousand Dollars (\$5,000), Contractor shall submit a Detailed Cost Breakdown (the total of which shall equal the full amount of the contract sum), and a list of all materials including the number of units to be installed and/or delivered and the price applicable thereto (which shall include, without limitation, delivery, transportation, placement, handling charges, labor, overhead and profit, etc.) in a form acceptable to the County. The Detailed Cost Breakdown shall be submitted to the County within ten (10) calendar days of the date of the County's Contract. The County shall have the right to withhold payment to Contractor until the Detailed Cost Breakdown is submitted by the Contractor.

**SECTION ONE**  
**INSTRUCTIONS TO BIDDERS AND GENERAL CONDITIONS OF CONTRACT**

---

**15. RECEIVING HOURS**

All shipments are to be made to the County in accordance with the instructions forwarded to the successful Bidder by the County. All deliveries shall be made between the hours of 8:00 a.m. and 2:30 p.m., Monday through Friday, except on County holidays.

**16. INSURANCE**

All Contractors doing work for the County shall carry such liability insurance as set forth below to fully protect the County against all claims which may arise. No work shall be started until the County has been provided Certificates of Insurance executed by an insurer licensed or approved to transact the business of insurance in the Commonwealth of Pennsylvania on a standard form provided by the insurer stating their intention to provide insurance to the Contractor in accordance with these insurance requirements. The Contractor shall at its own expense, purchase and maintain insurance in companies having an A- or better, or financial rating of IX or better with the A.M. Best's Company Key Rating Guide-Latest Edition and being satisfactory to the County. All Certificates of Insurance must indicate that the County, and its agents, if applicable, have (through endorsement to the policy) been specifically named as additional insured parties. The Certificate of Insurance must also provide that the policy will not be cancelled, materially changed, or allowed to expire until at least ten (10) days prior written notice, by certified mail, has been provided to the County, and its agents, if applicable. In addition, all of the Contractor's insurance policies and the Certificate of Insurance shall state that all of the Contractor's insurance policies are primary and non-contributory with respect to any other valid and collectible insurance policies. Failure to furnish the correct types of insurance on the correct forms in the correct amounts shall constitute a material breach of the conditions for award of the Contract and the Contractor shall be deemed to be in default.

**Bidders must provide with their bid a sample certificate of insurance evidencing, at minimum, the insurance coverage, types and levels set forth below.**

A. General Liability Insurance. General liability coverages shall be provided by commercial general liability policy on an occurrence basis. The policy date shall predate the Contract. The termination date of the policy or applicable extended reporting period shall be no earlier than the termination date of the Contract or later if otherwise specified in the Bid Documents. Where the Specifications require underground excavation, underground hazard coverage must be included. Where the Specifications require demolition and/or use of explosives, the explosion and collapse hazard coverage must be included.

- (i) Bodily Injury: \$1,000,000 each occurrence, \$2,000,000 aggregate
- (ii) Property Damage: \$1,000,000 each occurrence , \$2,000,000 aggregate

**SECTION ONE**  
**INSTRUCTIONS TO BIDDERS AND GENERAL CONDITIONS OF CONTRACT**

---

- B. Automobile Liability. (Including owned, non-owned and hired vehicles).
- (i) Bodily Injury: \$1,000,000 each occurrence.
  - (ii) Property Damage: \$1,000,000 each occurrence.
- C. Workers' Compensation and Employers' Liability.
- (i) Employers' Liability: \$500,000 each accident.  
\$500,000 disease policy limits.  
\$500,000 disease – each employee.
  - (ii) Statutory Limits for Workers' Compensation.
- D. Umbrella Excess Liability: \$2,000,000 for each occurrence and \$2,000,000 in the aggregate which provides excess coverage over all underlying insurance policies.
- E. Contractor's Pollution Liability: \$1,000,000 each loss  
\$1,000,000 aggregate  
Coverage to be provided for pollution claims resulting from the operations of the Contractor and any Subcontractors, as well as any materials or supplies brought onto the jobsite. Policies to include coverage for Bodily Injury, Property Damage, and Cleanup Costs. Including Mold Coverage and Asbestos Coverage

Contractor's failure to procure the necessary insurance and/or submit the required Certificates of Insurance, as stated above, within ten (10) calendar days of the County's Contract shall constitute a default by the Contractor, and the County may, at its sole discretion, award the Contract to the next lowest responsible Bidder, reserving to itself all rights for damages relating to said default, or, in the alternative, allow the Contractor additional time in which to secure the required insurance coverage. Other forms of insurance or changes in the amounts may be required in the Specifications.

Prior to commencement of the performance of the Contract, Contractor shall furnish to the County a certificate of insurance evidencing all required coverage in at least the limits required herein, **naming the County of Berks, its elected officials, agents, and employees as additional insureds for "ongoing operations" and "products and completed operations" for a period of three years after final payment under the Commercial General Liability Coverage. Coverage should be provided by ISO Endorsements CG20 10 07 04 and CG2037 07 04 or their equivalent. Contractor's Commercial General Liability and Umbrella/Excess Policy shall be Primary to and will not require contribution from any other insurance under which the Additional Insured is a Named Insured. To the fullest extent permitted by applicable state law, all policies shall contain a Waiver of Subrogation Clause.** The County of Berks reserves the

---

**SECTION ONE**  
**INSTRUCTIONS TO BIDDERS AND GENERAL CONDITIONS OF CONTRACT**

---

right to waive the waiver of subrogation for any and all worker's compensation policies that are provided under the State Worker's Insurance Fund (SWIF). The Certificate shall note the project and provide that no policies may be cancelled without ten (10) days advance written notice to the County. Such certificate shall be issued to: County of Berks, Attn: Contract Coordinator, 633 Court Street, 13<sup>th</sup> Floor Services Center, Reading, PA 19601. All insurance policies shall be in effect with companies holding an A.M. Best rating of "A-" or better or financial rating of IX or better with the A.M. Best's Company Key Rating, Guide Latest Edition and shall be licensed or authorized to do business in the Commonwealth of Pennsylvania. Such companies shall also be acceptable to the County. Said policies shall remain in full force and effect until the expiration of the terms of the contract or until completion of all duties to be performed hereunder by the Contractor, whichever shall occur later. Such certificate shall be issued to: County of Berks, Attn: Director, Contracts & Procurement, 633 Court Street, 13<sup>th</sup> Floor Services Center, Reading, PA 19601.

The Contractor's General Liability policy shall include the CG2503 Designated Construction Project's General Aggregate Limit or its equivalent.

The minimum coverage limits set forth herein shall be subject to periodic review, and the County reserves the right to require that the Contractor increase the minimum coverage limits if, in the reasonable opinion of the County, the minimum coverage limits become inadequate.

**17. FAMILIARITY WITH PROPOSED WORK**

The Contract is entered into by the County with the understanding that the Contractor, prior to submission of its Bid, acquainted itself with the requirements of all Bid Documents, all utilities in existence to which connections are to be made and other requirements of the Contract, and that the Contractor has obtained all necessary information for completion of the work on or before the date(s) specified. The Contractor shall not at any time after the execution of the Contract set up any claims whatsoever based upon insufficient data or incorrectly assumed conditions, nor shall the Contractor claim any misunderstanding in regard to the nature, conditions or character of the work to be done under the Contract, and Contractor shall assume all risk resulting from any changes in the conditions which may occur during the progress of the work.

**18. SAFETY DATA SHEETS; Right To Know Act**

Each Bidder submitting a Bid for any materials containing any hazardous substance listed on the Hazardous Substance List compiled by the Commonwealth of Pennsylvania, Department of Labor & Industry, must furnish appropriate material safety data sheets for all products for which they submit a Bid, along with the Bid. Failure to include the material safety data sheets with the Bid will void the Bid for that particular material. The County reserves the right to reject Bids for products that contain hazardous materials if, in the County's discretion, the product is too hazardous to be used. All successful Bidders shall comply with all other terms and conditions of the Pennsylvania Worker and Community Right-to-Know Act, Act No. 159 of 1984, 35 P.S. §7301

**SECTION ONE**  
**INSTRUCTIONS TO BIDDERS AND GENERAL CONDITIONS OF CONTRACT**

---

et seq., providing all information regarding the composition of all materials and products used or installed as part of the Project when required.

**19. HUMAN RELATIONS ACT**

For contracts for construction, alteration or repair of any public building or public work, the provisions of the Pennsylvania Human Relations Act, Act 222 of October 27, 1955, P.L. 744, 43 P.S. §951 *et seq.*, prohibit discrimination because of race, color, religious creed, ancestry, age, sex, national origin, handicap or disability, by employers, employment agencies, labor organizations, contractors and others. For contracts for construction, alteration or repair of any public building or public work, Contractor does hereby agree to comply with the provisions of the Pennsylvania Human Relations Act, as amended, which are hereby made part of all said contracts. Contractor's attention is directed to the language of the Commonwealth Non-Discrimination Clause as set forth in 16 Pa. Code §349.101.

**20. PREVAILING WAGE RATES**

A. For contracts for construction, reconstruction, demolition, alteration and/or repair work other than maintenance work, exceeding Twenty-Five Thousand Dollars (\$25,000), in accordance with the Pennsylvania Prevailing Wage Act, approved August 15, 1961, Act No. 442, P.L. 987, as amended by Act 342 of 1963, P.L. 653, 43 P.S. 165-1 *et seq.*, and the regulations issued pursuant thereto, the Prevailing Wage Rates as determined by the Secretary of the Department of Labor and Industry, Prevailing Wage Division of the State of Pennsylvania, for the locality of the work and for each classification of workers needed to perform the Contract shall apply, and workers shall be paid not less than these Prevailing Wage Rates. The provisions of the Pennsylvania Prevailing Wage Act, regulations and the Pennsylvania Prevailing Minimum Wage Rates, as determined by the Secretary of Labor and Industry, are made part of all said Contract.

B. If the project is subject to the Davis Bacon wage rates and the regulations issued pursuant thereto, the Prevailing Wage Rates as determined by the Administrator of the Wage and Hour Division of the U.S. Department of Labor, for the locality of the work and for each classification of workers needed to perform the Contract shall apply, and workers shall be paid not less than these Prevailing Wage Rates. The provisions of the Bacon Davis Act, regulations and the Prevailing Minimum Wage Rates, as determined by the Administrator of the Wage and Hour Division of the U.S. Department of Labor, are made part of all said Contract.

**21. DISCRIMINATION PROHIBITED**

According to Section 62 Pa.C.S.A. § 3701, the Contractor agrees that for any contracts entered into with the County for the construction, alteration or repair of any public building or public work shall contain the following provisions:

**SECTION ONE**  
**INSTRUCTIONS TO BIDDERS AND GENERAL CONDITIONS OF CONTRACT**

---

A. In the hiring of employees for the performance of work under the Contract, or any subcontract, no contractor, subcontractor, or any person acting on behalf of the contractor or subcontractor shall, by reason of gender, race, creed or color, discriminate against any citizen of the Commonwealth of Pennsylvania who is qualified and available to perform the work to which the employment relates.

B. No contractor, subcontractor, or any person acting on their behalf, shall in any manner discriminate against or intimidate any employee hired for the performance of work under the Contract on account of gender, race, creed or color.

C. The Contract may be canceled or terminated by the County, and all money due or to become due under the Contract may be forfeited, for a violation of the terms or conditions of that portion of the Contract.

D. The Contractor shall include the provisions of this Paragraph 21(a), (b) and (c) in every subcontract so that such provisions will be binding, upon each subcontractor.

E. Contractor and each subcontractor or any person acting on their behalf shall furnish necessary employment documents and records to and permit access to their books, records, and accounts by the County and the Bureau of Professional Selections and Administrative Services, for purposes of investigation, to ascertain compliance with the terms or conditions of the Contract. If the Contractor or any subcontractor does not possess documents or records reflecting the necessary information requested, the Contractor or subcontractor shall furnish such information on reporting forms supplied by the County or the Bureau of Professional Selections and Administrative Services.

**22. STEEL PRODUCTS PROCUREMENT**

For contracts for construction, reconstruction, alteration, repair, improvement or maintenance of public works, in accordance with the Pennsylvania Steel Products Procurement Act, Act No. 3 of 1978, P.L. 6, 73 P.S. § 1881 *et seq.*, if any steel or steel products are to be used or supplied in the performance of such contracts, only those produced in the United States as defined in the Pennsylvania Steel Products Procurement Act shall be used or supplied in the performance of the contracts or any subcontract thereunder. In accordance with Act 161 of 1982, cast iron products shall be included in the requirements pertaining to the production of steel product in the United States. In accordance with Act 141 of 1984, steel products shall be defined to include machinery and equipment listed in United States Department of Commerce Standard Industrial Classification 25 (furniture and fixtures), 35 (machinery, except electrical) and 37 (transportation equipment) and made of, fabricated from, or containing steel components. If a product contains both foreign and United States steel, such product shall be determined to be a United States steel product only if at least seventy-five percent (75%) of the cost of the articles, materials and supplies have been mined, produced or manufactured, as the case may be, in the

**SECTION ONE**  
**INSTRUCTIONS TO BIDDERS AND GENERAL CONDITIONS OF CONTRACT**

---

United States. Transportation equipment shall be determined to be a United States steel product if it complies with Section 165 of Public Law 97-424 (96 Stat. 2136).

**23. CASH ALLOWANCES**

No cash allowances for any purposes are included in the Specifications for this Project.

**24. PREVENTION OF ENVIRONMENTAL POLLUTION**

Section 3301 of the Pennsylvania Commonwealth Procurement Code requires that all invitations for Bids and requests for proposals for construction projects issued by any governmental agencies shall set forth any provision of federal and state statutes, rules, and regulations dealing with prevention of environmental pollution and the preservation of public natural resources that affect the Project. In this regard, attached to the Bid Documents is a list of Pennsylvania statutes. Contractor is hereby notified and agrees to comply with the terms of all statutes, rules and regulations that affect the Project on which Bids are being received. Each and every provision of law and clause required by law to be inserted in the Contract Documents shall be deemed to be inserted herein and the Contract Documents shall be read and enforced as though it were included herein, and if through mistake or otherwise such provision is not inserted, or is not correctly inserted, then upon the application of either party, the Contract Documents shall forthwith be physically amended to make such insertion.

**25. EROSION CONTROL**

Contractors performing excavation work shall comply with all rules and regulations of Chapter 102, Title 25 of the Pennsylvania Code (25 Pa. Code Section 102.1, et seq.), relating to soil erosion and sedimentation control. Prior to any grading, the Contractor shall be responsible to obtain approval from the Department of Environmental Resources for an approved sedimentation and erosion control site plan and shall perform all necessary site work in accordance with said plan. The plan shall be available at the site at all times. Contractors performing excavation work shall maintain all devices as required to control erosion caused by storm water and prevent dust and particles from being distributed on site.

**26. BLASTING**

All storage, handling and use of explosives for the purpose of excavation shall be performed by the Contractor in strict accordance with Title 25, Chapter 211, of the Pennsylvania Code, as well as any applicable local regulations. Strict control of blasting must be maintained to prevent flying rock, and blasting mats must be used where conditions dictate their use. When blasting in the vicinity of utility lines, such blasting must be performed according to Section 211.62 of Title 25 of the Pennsylvania Code.



**SECTION ONE**  
**INSTRUCTIONS TO BIDDERS AND GENERAL CONDITIONS OF CONTRACT**

---

**27. SITE EXCAVATION**

The Contractor shall:

A. Request the location and type of facility owner lines at the Project site by notifying the facility owner through the one call system as defined in 73 P.S. § 176. Notification shall be not less than three (3) business days nor more than ten (10) business days in advance of beginning excavation or demolition work. No work shall begin earlier than the scheduled excavation date which shall be on or after the third business day after notification. The scheduled excavation date shall exclude the date upon which notification was received by the one call system and notification received on a Saturday, Sunday or holiday, which shall be processed on the following business day. In the case of a complex project as defined in 73 P.S. § 176, notification shall not be less than ten (10) business days in advance of the beginning of excavation or demolition work.

B. Provide the one call system with specific information to identify the Project site so that facility owners might provide indications of their lines.

C. Take reasonable steps to work with facility owners including, without limitation, scheduling and conducting a preconstruction meeting, so that the Contractor may locate the facilities at a time reasonably in advance of the actual start of excavation or demolition work for each phase of the Work if the Project is a complex project as defined in 73 P.S. § 176 or if an excavation Contractor intends to perform work at multiple sites or over a large area. After commencement of excavation or demolition work, the excavation Contractor shall be responsible for protecting and preserving the staking, marking or other designation until no longer required for proper and safe excavation or demolition work at or near the underground facility, or by contacting the one call system to request that the facilities be marked again in the event that the previous markings have been compromised or eliminated.

D. Comply with the requirements established by the one call system regarding the maximum area that a notification may cover.

E. Inform each operator employed by the excavation Contractor at the Project site of the information received with respect to location and type of underground installations and any other information required by 73 P.S. § 176, et. seq.

F. Report immediately to the County, any break or leak on its lines or any dent, gouge, groove or other damage to such lines, to their coating or cathodic protection, made or discovered in the course of the excavation or demolition work.

G. Immediately notify 911 and the facility owner if the damage results in the escape of any flammable, toxic or corrosive gas or liquid which endangers life, health or property.

**SECTION ONE**  
**INSTRUCTIONS TO BIDDERS AND GENERAL CONDITIONS OF CONTRACT**

---

H. Assist a facility owner in determining involvement of a facility owner's lines by disclosing additional available information requested by the facility owner, including, without limitation, dimensions and the direction of proposed excavations.

I. Re-notify the one call system unless other arrangements have been made directly with the facility owners involved at the Project site if the excavation Contractor removes its equipment and vacates the Project site for more than two (2) business days.

J. Submit an incident report to the Department of Labor and Industry of the Commonwealth of Pennsylvania not more than ten (10) business days after striking or otherwise damaging a facility owner's line during excavation or demolition activities that resulted in personal injury or property damage to parties other than the affected excavation Contractor or facility owner.

K. Comply with all requests for information by the Department of Labor and Industry of the Commonwealth of Pennsylvania relating to such Department of Labor and Industry's enforcement authority under the 73 P.S. § 176, et. seq. within thirty (30) days of the receipt of the request.

L. Ensure the accuracy of the information provided to the one call system pursuant to 73 P.S. § 176, et. seq.

M. Become thoroughly acquainted with and comply with all other terms and conditions specified in 73 P.S. § 176, et. seq., as amended from time to time including, without limitation, the Contractor shall pay all applicable fees.

N. Complete the site excavation in full compliance with all applicable standards, codes, laws, ordinances, regulations and/or requirements of any applicable state, federal or governmental agency.

**28. WAIVER OF CONSEQUENTIAL AND INCIDENTAL DAMAGES; ECONOMIC LOSS**

The Contractor waives claims against the County for consequential and/or incidental damages arising out of or relating to the Contract. This waiver includes, but is not limited to:

A. Consequential damages incurred by the Contractor for principal office expenses including, but not limited to, the compensation of personnel stationed there, for losses of financing, business and reputation, and for loss of actual and expected profits.

B. Incidental damages incurred by the Contractor including, but not limited to, costs resulting from stopping performance under the Contract, removing and transporting the Contractor's property (e.g., the Contractor's equipment, supplies and materials) from the Project

---

**SECTION ONE**  
**INSTRUCTIONS TO BIDDERS AND GENERAL CONDITIONS OF CONTRACT**

---

site, and storing the Contractor's property (e.g., the Contractor's equipment, supplies and materials) at an alternate location.

This waiver is applicable, without limitation, to all consequential and/or incidental damages, due to either the Contractor and/or the County's termination of the Contract.

**29. FEES, PERMITS AND CERTIFICATIONS**

The Contractor shall pay for, secure and provide all necessary and required local, state and federal fees, permits and certificates.

**30. TAX EXEMPT STATUS**

A. Contractor shall be responsible for and shall pay all applicable sales, use, excise or other taxes required by law on all materials, tools, apparatus, equipment, fixtures, services, incidentals or otherwise which may be purchased or used in connection with the Work or portions thereof. The Bid shall be made in accordance with such laws and shall include all applicable taxes in the Bid amount.

Notwithstanding the foregoing, however, Owner is exempt (excluded) from sales and/or use tax in Pennsylvania on certain transactions. Contractor and all subcontractors shall bid and shall purchase as exempt (excluded) from Pennsylvania sales and/or use tax all tangible personal property within the definition of 'building machinery and equipment' as that term is defined in Act No. 45-1998 (72 P.S. § 7201 et seq.). Appendix "C" attached hereto and made a part hereof is a true and correct copy of the portion of such Act which defines the term "building machinery and equipment". No charges shall be allowed for such exempt items. It shall be the Contractor's responsibility to determine those items for which an exemption will apply, and the Contractor shall obtain legal or other tax advice to determine how and to what extent an exemption from the taxes apply. In order to facilitate such purchase free of sales and/or use tax in Pennsylvania, and upon certification by Contractor that an item is, in fact, tax exempt, the Owner agrees to execute a tax exemption certificate prepared by Contractor or a subcontractor as may be required by the regulations of the Pennsylvania Department of Revenue.

B. Assignment of Refund Rights.

Owner shall be entitled to claim refunds of sales and/or use tax paid on these and other purchases of tangible personal property required in connection with the Work. The Contractor and all subcontractors hereby assign to Owner all rights to any such refund claim and to any resulting refund and hereby appoint the Owner as their Attorney-in-Fact to execute and acknowledge in their respective names and to prosecute such refund claims before administrative agencies and courts in Pennsylvania having jurisdiction over such claims. The Owner or its agent shall have the right to review the books and records of the Contractor and all subcontractors for the purpose of documenting and substantiating any such refund claim. Contractor and all subcontractors shall

**SECTION ONE**  
**INSTRUCTIONS TO BIDDERS AND GENERAL CONDITIONS OF CONTRACT**

---

cooperate fully with Owner in pursuing any such refund claim and shall make available to the Owner any applicable documents.

C. Access to Accounting Records.

The Contractor shall check all materials, equipment and labor entering into the Work, and shall keep such full and detailed accounts as may be necessary for proper financial management under the Contract, and the system shall be satisfactory to Owner. The Owner or its representative shall be afforded access to, including the right to photocopy, all the Contractor's records, books, correspondence, instructions, drawings, receipts, vouchers, memoranda, and similar data relating to the Work, and the Contractor shall preserve all such records for a period of three (3) years, or for such longer period as may be required by the law, after receipt of final payment.

D. Contracts with Subcontractors.

The Contractor agrees to include the "Access to Accounting Records" and "Assignment of Refund Rights" paragraphs, in full, in any contracts with subcontractors. The Contractor further agrees that it will not file a claim for refund for any sales and/or use tax which is the subject of the assignment in Subparagraph B above. Contractor shall obtain from all subcontractors similar agreements that they will not file claims for refund for any sales and/or use tax which is the subject of the assignment in Subparagraph B above.

**31. ALL APPLICABLE LAWS, STATUTES, REGULATIONS AND STANDARDS**

Contractor shall comply with all applicable federal, state, local and industry statutes, regulations, ordinances, codes and standards. The failure to specifically reference or include said matters in the Contract Documents does not excuse Contractor from compliance with same.

**32. INDEMNIFICATION**

To the fullest extent permitted by law, the Contractor shall defend (with counsel reasonable acceptable to Owner), indemnify, hold harmless the County, its board members, agents, consultants, and their respective employees and agents from and against any and all claims, suits, demands, liabilities, damages, losses, Taxes and expenses, including, without limitation, legal fees and legal costs, arising out of or resulting from the Contractor's performance of the Contract, including, without limitation, claims, suits, demands, liabilities, damages, losses, Taxes and expenses attributable to bodily injury, sickness, disease or death, or to injury to or destruction of property, including, without limitation, loss of use resulting therefrom, caused in whole or in part by acts or omissions or negligence of the Contractor, its subcontractors, their respective officers, employees, agents, or anyone directly or indirectly employed by them or anyone for whose acts they may be liable, regardless of whether or not such claim, suit, demand, liability, damage, loss, Tax or expense is caused in part by the County. The indemnification obligation under this

---

**SECTION ONE**  
**INSTRUCTIONS TO BIDDERS AND GENERAL CONDITIONS OF CONTRACT**

---

paragraph shall not be limited by a limitation on amount or type of damages, compensation or benefits payable by or for the Contractor or a subcontractor under workers' or workmen's compensation acts, disability benefit acts or other employee benefit acts.

**33. TIME PERIOD FOR PERFORMANCE OF WORK**

Contractor shall order required material and perform other preconstruction activities upon issuance of the Notice to Proceed (NTP) issued by the County. The County shall not issue the NTP until such time as the agreement is fully executed between County and Contractor. All Contract Work shall be completed within sixty (60) calendar days following the issuance of the NTP. Notwithstanding the foregoing, the County reserves the right, upon notice to the Contractor, to extend the Contract or any part of the Contract for up to three (3) months upon the same terms and conditions as the County deems necessary in its sole and absolute discretion. This will be utilized to prevent a lapse in Contract coverage and only for the time necessary, up to three (3) months, to enter into a new contract.

**34. PAYMENT**

A. Contractors will be paid according to the schedule below, provided all work for which payment is requested has been completed in accordance with the Contract Documents and Contractor is in full compliance with all requirements of the Contract. Invoices must be received by the end of each calendar month, and will be authorized for payment by the Board of Commissioners for the County at the following calendar months regular meeting.

Amount of Contract	Payment Schedule for Specified Projects	Payment Schedule for Annual Contract
Under \$5,000	100% upon completion of specified work.	Annually
\$5,000 to \$20,000	Upon completion of 50% of specified work, respective payment amount shall be made, less retainage. Upon completion of 100% of specified work, remaining payment amount shall be made. Payments shall be subject to conditions of paragraph B hereof.	Semi-Annually
\$20,001 to \$50,000	Upon completion of 25%, 50% and 75% of work, respective payment amount shall be made, less retainage. Upon completion of 100% of	Quarterly

**SECTION ONE**  
**INSTRUCTIONS TO BIDDERS AND GENERAL CONDITIONS OF CONTRACT**

	specified work, remaining payment amount shall be paid. Payments shall be subject to paragraph B hereof.	
Over \$50,000	Payments shall be made monthly upon completion of specified work, less retainage as per paragraph C hereof.	Monthly

B. For any Contract from Five Thousand Dollars (\$5,000) to Fifty Thousand Dollars (\$50,000), payment will be made only after the Detailed Cost Breakdown (reference Paragraph 14 hereof) has been provided by Contractor and approved by the County. Payments shall be made only for work completed according to the Detailed Cost Breakdown. Five percent (5%) retainage shall be withheld by the County for all payments prior to final completion. Upon final completion to the satisfaction and acceptance by the County, in the County’s sole and absolute discretion, final payment, including retainage, shall be made.

C. For any Contract in excess of Fifty Thousand Dollars (\$50,000), payment will be made only after the Detailed Cost Breakdown (reference Paragraph 14 hereof) has been provided by the Contractor and approved by the County. Payments shall be made only for work completed according to the Detailed Cost Breakdown. Retainage in the amount of ten percent (10%) of the value of the completed work, based on monthly progress payments, shall be withheld by the County during the first fifty percent (50%) of the Contract. Except as otherwise provided herein, when the Contract is fifty percent (50%) completed, one-half (1/2) of the amount retained by the County shall be returned to the Contractor, provided that the County approves the application for payment, and further provided that the Contractor is making satisfactory progress and that there is no specific cause for greater withholding.

Notwithstanding the foregoing, the County may continue to withhold ten percent (10%) of the amount due the Contractor after the Contract is fifty percent (50%) completed if the County determines in its sole and absolute discretion that there is a specific cause for greater withholding. A specific cause for greater withholding shall include, without limitation, the following:

- (1) The Contractor’s inability to produce evidence satisfactory to the County evidencing payments for materials, labor and/or payments to Subcontractors, manufacturers or suppliers;
- (2) The existence of a dispute between the County and the Contractor regarding increased costs claimed by such Contractor; or
- (3) A Contractor’s failure to complete the work in accordance with the Contract Documents, including, without limitation, the Plans and Specifications, etc.

**SECTION ONE**  
**INSTRUCTIONS TO BIDDERS AND GENERAL CONDITIONS OF CONTRACT**

---

If a specific cause for greater withholding does not exist, the sum or sums withheld by the County from the Contractor, after the Contract is fifty percent (50%) completed, shall be reduced to five percent (5%) of the value of the completed work based on monthly progress payments. In the event a dispute arises between the County and the Contractor, which dispute is based upon any of the items set forth in this Paragraph 34, the County shall have the option as it deems necessary in its sole and absolute discretion to either continue to withhold additional retainage over and above the amount already retained by the County in the sum of one and one-half (1-1/2) times the amount of any possible liability until such time as a final resolution is agreed to by all parties directly or indirectly involved, unless the Contractor causing the additional claim furnishes a bond satisfactory to the County to indemnify the County, its board members, agents, consultants, and their respective employees and agents against the claim. All money retained by the County may be withheld from the Contractor until final completion of the Contract.

D. A continuing Contract providing for daily, weekly or monthly services shall be paid on a monthly basis.

**35. TIME OF FINAL COMPLETION**

For specific projects, the date set for final completion of the Contract is designated Clause 33. Time is of the essence in completing all work and provisions for liquidated damages in the event of any delay in completing the Contract may be provided for in the Specifications.

**36. FAILURE TO FINISH OR COMPLETE CONTRACT**

In the event Contractor shall neglect or refuse to complete the Project as required, or any part thereof, or to replace any work which is rejected, then the County is authorized and empowered to purchase materials, equipment and services from third parties, and in such manner as it shall elect at the expense of the Contractor, or to cancel the Contract; reserving to itself, nevertheless, all rights for damages, including, without limitation, legal fees, legal costs, and additional professional costs, which may be incurred by the County.

**37. CLEAN-UP/DAMAGE TO PREMISES**

A. Where work is to be performed by Contractor on County premises, Contractor shall keep the County's premises free from accumulation of waste materials or rubbish caused by the Contractor's performance. At final completion of the work, Contractor shall remove from and about the premises, all waste materials, rubbish, Contractor's tools, construction equipment, machinery and surplus materials. If the Contractor fails to clean up as provided herein, the County may do so, and the costs thereof shall be charged to the Contractor.

B. Contractor shall promptly remedy damage and loss to any County building or equipment caused in whole or in part by the Contractor, or anyone directly or indirectly employed by him.

**SECTION ONE**  
**INSTRUCTIONS TO BIDDERS AND GENERAL CONDITIONS OF CONTRACT**

---

**38. WARRANTY**

All work shall be guaranteed by Contractor against defects in workmanship and materials for a period of one (1) year from the date of acceptance by the County. During this period, Contractor shall agree to promptly remedy, at Contractor's expense, any defects which were caused, in the judgment of the County, by defective or inferior workmanship or materials.

**39. SUBLETTING OR ASSIGNING OF CONTRACTOR**

The Contractor shall not sublet, sell, transfer, assign, or otherwise dispose of the Contract, or any portion thereof, or of its right, title, or interest therein without the written consent of the County.

**40. DELAY AND EXTENSIONS OF TIME.**

If Contractor is delayed at any time in the progress of the work by any act or neglect of the County, its agents or employees, any separate Contractor employed by the County or by changes ordered in the work, labor disputes, fire, unusual delay in transportation, adverse weather conditions not reasonably anticipated, unavoidable casualties or by any other cause beyond the control of the Contractor, Contractor's exclusive remedy shall be an extension of time allowed for final completion of the work under the Contract. This extension of time shall not act as an entitlement for damages due and owing the Contractor for said delay. Under no circumstances shall Contractor be entitled to claim or recover payment, compensation or damages for any delays from any cause whatsoever in the progress of the work, notwithstanding whether such delays be avoidable or unavoidable.

**41. GOVERNING LAW.**

The Contract shall be governed by the law of the Commonwealth of Pennsylvania, without regard to principles of conflict of laws.

**42. CLAIMS AND DISPUTES.**

A. Claims, disputes or other matters in question between the parties to the Contract arising out of or relating to the Contract or breach thereof shall be exclusively litigated in the Court of Common Pleas of Berks County.

B. Pending resolution of any claim and/or dispute, unless otherwise agreed in writing, Contractor shall proceed diligently with performance of the Contract so as to avoid delay in the schedule of completion of the Project.



**SECTION ONE**  
**INSTRUCTIONS TO BIDDERS AND GENERAL CONDITIONS OF CONTRACT**

---

C. To the extent the Contractor pursues a claim or litigation against the County and the County prevails, partially or completely, on any or all of its own claims or defenses to the Contractor's claims, leaving the Contractor with less than one hundred percent (100%) recovery, the Contractor will be liable for any and all legal fees, professional fees, costs or expenses of the County, as well as the true cost of any of the County's employees' time, associated with analyzing any claim, pursuing litigation or defending the claim or litigation. Further, to the extent any Contractor makes an excessive number of claims, which excessiveness, shall be determined solely in the discretion of the County, and the County incurs any legal fees, professional fees, expenses, costs (including, but not limited to, employee cost), the Contractor shall be liable for such fees, expenses or costs. In the event of a dispute between the Contractor and the County, to the extent that the County incurs any legal fees, professional fees, or other costs or expenses, the Contractor will be responsible for those amounts, which will be deducted, to the extent available, from any amount due the Contractor. If the amount due the Contractor is not sufficient to cover such cost, the Contractor shall pay the difference to the County within seven (7) days of receipt of the County's invoice for such legal fees, professional fees, or other cost or expenses.

D. The Contractor and Contractor's Surety shall be liable for and shall pay the County the cost of expenses incurred by the County resulting from the Contractor's delay in completing the Contract within the contract time, as liquidated damages, and not as a penalty, in the amount of Two Hundred Dollars and Zero Cents (\$200.00) per calendar day, for each calendar day of delay until the work is substantially complete at each phase of construction, subject to adjustments of the contract time as provided in the Contract Documents. In the event the Contractor or Surety litigates the validity of this provision or the assertion of liquidated damages, the Contractor and Surety, jointly and severally, shall also be liable for legal fees, professional fees, costs, other expenses and/or damages. This liquidated damages provision applies to each phase of construction. The County's right to receive liquidated damages shall be in addition to all other rights and remedies available to the County at law or in equity. The County shall have the right to deduct the total amount of liquidated damages for which the Contractor may be liable under this Paragraph 42(D) from any payments then or thereafter due the Contractor.

**43. WAIVER OF CLAIMS.**

The making and acceptance of final payment shall constitute a waiver of all claims by Contractor against the County other than those previously made in writing and specifically identified by Contractor as unsettled at the time of application for final payment.

**44. TERMINATION OF CONTRACT.**

Upon ten (10) days written notice to Contractor, the County may, without cause and without prejudice to any other right or remedy, elect to terminate the Contract. Upon receipt of written notice from the County of such termination, Contractor shall cease operations as directed by the County in the notice; take actions necessary, or that the County may direct, for the protection and preservation of the work; and except for work directed to be performed prior to the effective

**SECTION ONE**  
**INSTRUCTIONS TO BIDDERS AND GENERAL CONDITIONS OF CONTRACT**

---

date of termination stated in the notice, terminate all existing subcontracts and Contracts and enter into no further subcontracts and Contracts. In case of such termination, where Contractor is without fault, Contractor shall be entitled to receive payment from the County for all work satisfactorily performed prior to termination.

**45. PENNSYLVANIA UNIFORM CONSTRUCTION CODE.**

The Contractor shall comply with all requirements of the Pennsylvania Uniform Construction Code, 35 P.S. § 7210.301 – 7210.305, as amended by S.B. 1139, Session of 2004.

**46. PENNSYLVANIA PROMPT PAY ACT.**

The Contractor hereby waives any rights that the Contractor has or may have under the Pennsylvania Prompt Pay Act, 62 Pa. C.S.A. § 3931, et seq., as amended from time to time.

**47. WORKER PROTECTION AND INVESTMENT**

To the extent applicable, Bidder shall comply with Commonwealth of Pennsylvania Executive Order 2021-06, Worker Protection and Investment, and certify Bidder is in compliance with all applicable Pennsylvania state labor and workforce safety laws including:

- A. Construction Workplace Misclassification Act;
- B. Employment of Minors Child Labor Act;
- C. Minimum Wage Act;
- D. Prevailing Wage Act;
- E. Equal Pay Law;
- F. Employer to Pay Employment Medical Examination Fee Act;
- G. Seasonal Farm Labor Act;
- H. Wage Payment and Collection Law;
- I. Industrial Homework Law;
- J. Construction Industry Employee Verification Act;
- K. Act 102: Prohibition on Excessive Overtime in Healthcare;
- L. Apprenticeship and Training Act; and

**SECTION ONE**  
**INSTRUCTIONS TO BIDDERS AND GENERAL CONDITIONS OF CONTRACT**

---

M. Inspection of Employment Records Law.

Vendor shall also certify compliance with Unemployment Compensation tax requirements and Workers' Compensation insurance requirements.

**48. INTERPRETATIONS**

A. Where required hereunder to effectuate the intent of the Contract Documents, masculine shall mean neuter or feminine and the singular shall mean the plural.

B. The captions and headings of various Paragraphs in the Contract Documents are for convenience only and are not to be construed as defining or limiting, in any way, the scope or intent of the provisions hereof.

C. The invalidity of any covenant, restriction, condition, limitation or any other part or provision of the Contract Documents shall not impair or affect in any manner the validity, enforceability or effect of the remainder of the Contract Documents.

D. The parties hereto acknowledge that all of them have participated in the drafting of the Contract Documents and the parties hereto expressly waive the defense of *contra proferentum*, *i.e.*, that the Contract Documents or any portion of the Contract Documents may be construed against any party as the drafter thereof.

**NOTICE: BIDS ARE PUBLICLY OPENED AND READ ON THE DATE SPECIFIED. IF YOU ARE INTERESTED IN IMMEDIATE INFORMATION RELATING TO THE BID, PLEASE HAVE A REPRESENTATIVE PRESENT AT BID OPENING. QUESTIONS AND LOW BID INFORMATION WILL BE AVAILABLE DURING BID OPENING. FOLLOWING BID OPENING, THE BIDS WILL BE REVIEWED BY THE APPROPRIATE AUTHORITIES OF AND FOR COUNTY OF BERKS. THEREFORE, INFORMATION ON THE BIDS WILL NOT AGAIN BE AVAILABLE UNTIL THEY HAVE BEEN REVIEWED AND A FINAL RECOMMENDATION IS PRESENTED TO THE BOARD OF COMMISSIONERS OF THE COUNTY OF BERKS AT ITS REGULARLY SCHEDULED MEETING.**

**SECTION TWO  
ADVERTISEMENT FOR BIDS**

---

**Invitation to Bid #24-08-GR  
Wertz Covered Bridge Stair Replacement Project**

The **County of Berks** is accepting sealed bids from qualified bidders for the Wertz Covered Bridge Stair Replacement Project. Bids will be accepted by the County, c/o County Controller, Berks County Services Center, 633 Court Street, 12th Floor, Reading, PA, 19601, until 2:00 P.M. on Thursday, May 2, 2024. Bids will be opened publicly at 2:15 P.M. on Thursday, May 2, 2024. Members of the public may attend the bid opening through a Microsoft Teams meeting. The Microsoft Teams URL for the opening can be located within the ITB and on the following site under the listing for this specific ITB:

<https://www.berkspa.gov/departments/purchasing/itb-rfp>. Each bid must be accompanied by bid security in the amount and form specified in the ITB package.

A pre-bid conference will be held on Wednesday, April 3, 2024 beginning promptly at 10:00 A.M onsite at the Wertz Covered Bridge located at the Red Bridge Recreation Area at 2141 Tulpehocken Road, Wyomissing, PA 19610. Details can be found in the above notated ITB. Bidders may obtain the ITB package via the following methods: (1) download the ITB package from the County's website [www.berkspa.gov](http://www.berkspa.gov) or (2) call the County's Purchasing Dept at 610-478-6168 to request the package. The County reserves the right to reject any or all bids or any part thereof and/or waive any informality in any bid received when such action is in the best interest of the County.

Kelly A. Laubach, CPPB  
Director of Contracts and Procurement  
Tel: 610-478-6168

**SECTION THREE**  
**TECHNICAL SPECIFICATIONS**

---

1. DIVISION 01 – GENERAL REQUIREMENTS

1.1. Section 01011 - Summary of Project

1.1.1. Statement of Work

1.1.1.1. The Contractor shall be solely responsible for furnishing all administration, shop drawings, materials, equipment, labor, supplies, mobilization and supervision for the performance of the work of this contract.

1.1.2. Description of Work

1.1.2.1. NOTE: The Contractor shall ensure a copy of this Section, “Description of Work” shall be on site with the various crew foreman including subcontractors at all times. It shall be the responsibility of each crew foreman to familiarize themselves with the following scopes of work and specifications.

1.1.2.2. The Work shall include, but not necessarily be limited to, furnishing all materials, equipment, mobilization, supervision, labor, surface preparation, and any/all incidental work as necessary for the proper construction and installation for the replacement of stairs at Wertz’s Covered Bridge.

1.1.2.2.1. Wertz’s Covered Bridge Stair Replacement

1.1.2.2.1.1. Perform demolition of existing stairs and properly dispose of the removed materials.

1.1.2.2.1.2. Provide all survey / layout work for the new stair posts. Review layout with Owner prior to excavation for posts.

1.1.2.2.1.3. Provide all excavation for the post installation. Provide all concrete footing pads and crushed stone backfill as noted on the plans.

1.1.2.2.1.4. Provide all pressure-treated wood posts, framing, stair tread and risers, platform decking and railing / guard framing. Provide all aluminum handrails and brackets at stairs.

1.1.2.2.1.5. Provide all final grading at the bottom and top landings using stone screenings to match the existing pathways. Provide all

## SECTION THREE TECHNICAL SPECIFICATIONS

---

final grading around project area to restore existing bank grades.

- 1.1.2.2.2. The Contractor shall coordinate and schedule the work on site with the Owner. Work shall be performed during normal working hours from 7:00 a.m. thru 4:00 p.m. during the normal work week of Monday through Friday.
- 1.1.2.2.3. All work shall be performed in accordance with the requirements of the Uniform Construction Code, with particular note of the requirements of the International Mechanical Code.
- 1.1.2.2.4. The Contractor is responsible to complete the applicable Municipal permits for this project.

### 1.1.3. Work Sequence

- 1.1.3.1. The Contractor shall submit his proposed sequence and schedule of work at the Pre-Construction Conference.

## 1.2. Section 01039 - Coordination and Meetings

### 1.2.1. Coordination

- 1.2.1.1. Coordinate scheduling, submittals, and Work of the various Sections of Specifications to assure efficient and orderly sequence of installation of interdependent construction elements.
- 1.2.1.2. Coordinate completion and clean-up of Work of separate sections in preparation for Substantial Completion.

### 1.2.2. Field Engineering

- 1.2.2.1. The Contractor shall perform all layout work required for the completion of the Project.
- 1.2.2.2. The Contractor shall furnish, free of charge, all templates and other materials, place such additional stakes and markers necessary for control and guidance of construction operations. The Contractor shall also furnish the Engineer with such assistance as may be required for checking all lines, and measurements established (by the Contractor) and necessary in the prosecution of the Work. Such checking by the Engineer is not relief

**SECTION THREE**  
**TECHNICAL SPECIFICATIONS**

---

of responsibility to perform all Work in accordance with the Drawings, Specifications, and the lines and grades given.

- 1.2.2.3. There shall be no separate payment for this work. This work is incidental to the completion of the project.

1.2.3. Pre-Construction Conference

- 1.2.3.1. Engineer will schedule a conference after issuance of the Notice to Proceed.

- 1.2.3.2. Attendance Required: Owner, Engineer, and Contractor.

- 1.2.3.3. Agenda:

- 1.2.3.3.1. Distribution of Contract Documents.

- 1.2.3.3.2. Submission of list of Subcontractors and progress schedule.

- 1.2.3.3.3. Designation of personnel representing the parties in the Contract, and the Engineer.

- 1.2.3.3.4. Procedures and processing of field decisions, submittals, substitutions, applications for payments, proposal request, Change Orders and Contract closeout procedures.

- 1.2.3.3.5. Scheduling.

1.3. Section 01300 - Administrative Requirements

1.3.1. Progress Meetings

- 1.3.1.1. Engineer shall make arrangements for meetings, prepare agenda with copies for participants, and preside at meetings. Meetings will be scheduled on an “as needed” basis as derived by the Engineer.

- 1.3.1.2. Attendance Required: Job superintendent, major subcontractors and suppliers, Engineer as appropriate to agenda topics for each meeting.

- 1.3.1.3. Agenda:

- 1.3.1.3.1. Review minutes of previous meetings.

**SECTION THREE**  
**TECHNICAL SPECIFICATIONS**

---

- 1.3.1.3.2. Review of Work progress.
- 1.3.1.3.3. Field observations, problems, and decisions.
- 1.3.1.3.4. Identification of problems impeding planned progress.
- 1.3.1.3.5. Review of submittals schedule and status of submittals.
- 1.3.1.3.6. Review of off-site fabrication and delivery schedules.
- 1.3.1.3.7. Maintenance of progress schedule.
- 1.3.1.3.8. Corrective measures to regain projected schedules.
- 1.3.1.3.9. Planned progress during succeeding work period.
- 1.3.1.3.10. Coordination of projected progress.
- 1.3.1.3.11. Maintenance of quality and work standards.
- 1.3.1.3.12. Effect of proposed changes on progress schedule and coordination.
- 1.3.1.3.13. Other business relating to Work.
- 1.3.1.4. Record minutes and distribute copies within two days after meeting to participants, with two copies to Engineer, Owner, and those affected by decisions made.

1.3.2. Execution

1.3.2.1. Cutting and Patching

- 1.3.2.1.1. Employ skilled and experienced installer to perform cutting and patching.
- 1.3.2.1.2. Submit written request in advance of cutting or altering elements affecting:
  - 1.3.2.1.2.1. Structural integrity of element.
  - 1.3.2.1.2.2. Integrity of weather-exposed or moisture-resistant elements.
  - 1.3.2.1.2.3. Efficiency, maintenance, or safety of element.



**SECTION THREE**  
**TECHNICAL SPECIFICATIONS**

---

- 1.3.2.1.2.4. Visual qualities of sight exposed elements.
- 1.3.2.1.2.5. Work of Owner or separate contractor.
- 1.3.2.1.3. Execute cutting, fitting, and patching to complete Work, and to:
  - 1.3.2.1.3.1. Fit the several parts together, to integrate with other Work.
  - 1.3.2.1.3.2. Uncover Work to install or correct ill-timed Work.
  - 1.3.2.1.3.3. Remove and replace defective and non-conforming Work.
  - 1.3.2.1.3.4. Remove samples of installed Work for testing.
  - 1.3.2.1.3.5. Provide openings in elements of Work for penetrations of mechanical and electrical Work.
- 1.3.2.1.4. Execute work by methods to avoid damage to other Work, and to provide proper surfaces to receive patching and finishing.
- 1.3.2.1.5. Cut masonry and concrete materials using masonry saw or core drill.
- 1.3.2.1.6. Restore Work with new products in accordance with requirements of Contract Documents.
- 1.3.2.1.7. Refinish surfaces to match adjacent finishes. For continuous surfaces, refinish to nearest intersection; for assembly, refinish entire unit.
- 1.3.2.1.8. Identify hazardous substances or conditions exposed during the Work to Engineer for decision or remedy.
- 1.3.2.2. Special Procedures
  - 1.3.2.2.1. Materials: As specified in product sections; match existing with new products for patching and extending work.
  - 1.3.2.2.2. Employ skilled and experienced installer to perform alteration work.
  - 1.3.2.2.3. Cut, move, or remove items as necessary for access to alterations and renovation Work. Replace and restore at completion.

**SECTION THREE**  
**TECHNICAL SPECIFICATIONS**

---

- 1.3.2.2.4. Remove unsuitable material not marked for salvage, including rotted wood, corroded metals, and deteriorated masonry and concrete. Replace materials as specified for finished Work.
- 1.3.2.2.5. Remove debris and items from construction area.
- 1.3.2.2.6. Prepare surface and remove surface finishes to permit installation of new work and finishes.
- 1.3.2.2.7. Protect existing work from weather and conditions and secure work area at all times.
- 1.3.2.2.8. Remove, cut and patch Work in manner to minimize damage and to permit restoring products and finishes to original condition.
- 1.3.2.2.9. Where new Work abuts or aligns with existing, provide smooth and even transition. Patch Work to match existing adjacent Work in texture and appearance.

1.4. Section 01330 - Construction Work Submittals

1.4.1. Construction Work Submittal Procedures

- 1.4.1.1. Transmit each submittal with Engineer accepted form.
- 1.4.1.2. Sequentially number the transmittal forms. Resubmittals to have original number with an alphabetic suffix.
- 1.4.1.3. Identify Project, Contractor, Subcontractor or supplier; pertinent Drawing sheet and detail number(s), and specification Section number, as appropriate.
- 1.4.1.4. Apply Contractor's stamp, signed or initialed certifying that review, verification of Products required, field dimensions, adjacent construction Work, and coordination of information, is in accordance with the requirements of the Work and Contract Documents.
- 1.4.1.5. Schedule submittals to expedite the Project, and deliver to Engineer at business address. Coordinate submission of related items.
- 1.4.1.6. Identify variations from Contract Documents and Product or system limitations which may be detrimental to successful performance of the completed Work.

**SECTION THREE**  
**TECHNICAL SPECIFICATIONS**

---

- 1.4.1.7. Provide space for Contractor and Engineer review stamps.
- 1.4.1.8. Revise and resubmit submittals as required, identify all changes made since previous submittal.
- 1.4.1.9. Distribute copies of reviewed submittals to concerned parties. Instruct parties to promptly report any inability to comply with provisions.
- 1.4.2. Construction Progress Schedules
  - 1.4.2.1. Submit initial progress schedule in triplicate at preconstruction conference for Engineer review.
  - 1.4.2.2. Revise and resubmit as required.
- 1.4.3. Shop Drawings/Submittals
  - 1.4.3.1. Submit in triplicate.
  - 1.4.3.2. After review, reproduce and distribute in accordance with Article on Procedures above.
  - 1.4.3.3. Provide the following shop drawings for review and approval:
    - 1.4.3.3.1. Aluminum handrails and brackets.
    - 1.4.3.3.2. Documentation on pressure treatment for wood posts.
- 1.5. Section 01400 - Quality Control
  - 1.5.1. Quality Assurance and Control of Installation
    - 1.5.1.1. Monitor quality control over suppliers, manufacturers, Products, services, site conditions, and workmanship, to product Work of specified quality.
    - 1.5.1.2. Comply with specified standards as a minimum quality for the Work except when more stringent tolerances, codes, or specified requirements indicate higher standards or more precise workmanship.
    - 1.5.1.3. Perform work by persons qualified to produce workmanship of specified quality.

**SECTION THREE**  
**TECHNICAL SPECIFICATIONS**

---

1.5.2. References

- 1.5.2.1. Obtain copies of standards when required by Contract.
- 1.5.2.2. Should specified reference standards conflict with Contract, request clarification for Engineer before proceeding.
- 1.5.2.3. The contractual relationship of the parties to the Contract shall not be altered from the Contract by mention or inference otherwise in any reference document.

1.5.3. Inspection and Testing Laboratory Services

- 1.5.3.1. Contractor shall provide for any inspection or testing by others, at no additional expense to the Owner.

1.6. Section 01700 - Contract Closeout

1.6.1. Closeout Procedures

- 1.6.1.1. Upon completion of the Work under this Contract, the Engineer shall make an inspection to determine if the Work is fully and satisfactorily completed.
- 1.6.1.2. Submit written certification that Contract Documents have been reviewed, Work has been inspected, and that Work is complete in accordance with Contract Documents and ready for Engineer's inspection.
- 1.6.1.3. Provide submittals to Engineer that are required by governing or other authorities.
- 1.6.1.4. Submit final Application for Payment identifying total adjusted Contract Sum, previous payments, and sum remaining due.

1.6.2. Final Cleaning

- 1.6.2.1. Execute final cleaning and site restoration prior to final inspection.
- 1.6.2.2. Clean site; sweep paved areas.
- 1.6.2.3. Remove waste and surplus materials, rubbish, and construction facilities from the site.

**SECTION THREE**  
**TECHNICAL SPECIFICATIONS**

---

- 1.6.2.4. Remove all temporary services and facilities used during construction prior to final inspection.

2. DIVISION 02 – SITE WORK

2.1. Section 02060 - Removal and Demolition of Existing Facilities

2.1.1. Part 1 – General

2.1.1.1. Section Includes:

- 2.1.1.1.1. Demolish designated structures.

- 2.1.1.1.2. Remove materials from site.

2.1.1.2. Related Sections:

- 2.1.1.2.1. Section 02200 – Excavation and Earthwork: Backfill materials.

2.1.1.3. Existing Conditions.

- 2.1.1.3.1. Conduct demolition to minimize interference with Owner operations at the site.

- 2.1.1.3.2. Provide, erect, and maintain temporary barriers and security devices.

- 2.1.1.3.3. Conduct operations with minimum interference to public or private thoroughfares. Maintain egress and access at all times.

- 2.1.1.3.4. Do not close or obstruct roadways without permits.

2.1.2. Part 2 – Products (Not Used)

2.1.3. Part 3 – Execution

2.1.3.1. Preparation

- 2.1.3.1.1. Inspect facilities prior to start of work; verify with the Engineer the objects being removed and salvaged and objects to be preserved.

- 2.1.3.1.2. Do not start work without prior approval of the Engineer.

**SECTION THREE  
TECHNICAL SPECIFICATIONS**

---

2.1.3.1.3 Prevent movement or settlement of adjacent structures. Provide bracing and shoring as required to prevent movement.

2.1.3.1.4. Protect existing landscaping materials and structures which are not to be demolished.

2.1.3.2. Execution

2.1.3.2.1. Demolish indicated structures and appurtenances in an orderly and careful manner.

2.1.3.2.2. Cease operations and notify Engineer immediately if adjacent structures appear to be endangered. Do not resume operations until corrective measures have been taken.

2.1.3.2.3. Except where noted otherwise, immediately remove demolished material from site.

2.1.3.2.4. Remove and promptly dispose of contaminated, vermin infested, or dangerous materials encountered.

2.1.3.2.5. Do not burn or bury materials on site.

2.1.3.2.6. Rough grade and compact areas affected by demolition to provide drainage.

2.1.3.2.7. Remove demolished materials from site as work progresses. Leave site in clean condition.

2.1.3.2.8. All demolition wastes shall be disposed of in an approved Pennsylvania Department of Environmental Protection method (i.e., landfilling). Any permits necessary can be obtained in the name of the Owner, but the Contractor will be responsible for all permit and laboratory analysis fees.

2.2. Section 02200 – Excavation and Earthwork

2.2.1. Part 1 – General

2.2.1.1. Section Includes:

2.2.1.1.1. Clearing and Grubbing;

---

**SECTION THREE**  
**TECHNICAL SPECIFICATIONS**

---

2.2.1.1.2. Rock Excavation;

2.2.1.1.3. Excavation;

2.2.1.1.4. Backfilling; and

2.2.1.1.5. Rough Grading.

2.2.1.2. Related Sections.

2.2.1.2.1. Section 03300 - Cast-in-Place Concrete.

2.2.1.3. References.

2.2.1.3.1. ASTM C136 - Sieve Analysis of Fine and Coarse Aggregates.

2.2.1.3.2. ASTM D1556 - Density of Soil in Place by the Sand Cone Method.

2.2.1.3.3. ASTM D1557 - Moisture-Density Relations of Soils and Soil-Aggregate Mixtures Using 10 Pound Rammer and 18-inch Drop.

2.2.1.3.4. ASTM D2167 - Density of Soil in Place by the Rubber Balloon Method.

2.2.1.3.5. ASTM D2487 - Classification of Soils for Engineering Purposes.

2.2.1.3.6. ASTM D2922 - Density of Soil and Soil Aggregate in place by Nuclear Methods.

2.2.1.3.7. ASTM D4318 - Test Methods for Liquid Limit, Plastic Limit and Plasticity Index of Soils.

2.2.1.3.8. NFPA 495 - Manufacture, Transportation, Storage and Use of Explosives.

2.2.1.3.9. AASHTO - M14 - Materials for Aggregate and Soil Aggregate.

### SECTION THREE TECHNICAL SPECIFICATIONS

---

#### 2.2.1.4. Quality Assurance.

- 2.2.1.4.1. All blasting of subsurface rock must be performed under the supervision and direct control of a licensed blaster with a minimum of five years of documented experience.
- 2.2.1.4.2. All filling and backfilling and subgrade may be laboratory and field tested to verify compaction requirements and conformance with specifications. Testing shall be done in accordance with Section 01400, Quality Assurance.
- 2.2.1.4.3. Provide materials of each type from same source throughout the work.

#### 2.2.1.5. Regulatory Requirements.

- 2.2.1.5.1. Conform to local code requirements for disposal and/or burning of debris.
- 2.2.1.5.2. Obtain permits from authorities having jurisdiction before explosives are brought to site or drilling is started.
- 2.2.1.5.3. Comply with all state, county and local regulations governing use of explosives for removal of subsurface rock.
- 2.2.1.5.4. Rules and regulations of the various utility companies and other authorities having jurisdiction over such Work shall be observed in the performance of all earthwork operations.

#### 2.2.1.6. Examination.

- 2.2.1.6.1. Verify site conditions prior to starting work.
- 2.2.1.6.2. Verify that survey benchmark and intended elevations for the work are as indicated.

#### 2.2.1.7. Protection.

- 2.2.1.7.1. Do not damage or disturb any existing monuments, benchmarks, structures, fences, sidewalks, paving and curbs and other markers. Provide suitable protection where required before starting Work. Restore any damage to its original condition or repair as directed by Engineer and/or Owner at Contractor's expense.



### SECTION THREE TECHNICAL SPECIFICATIONS

---

- 2.2.1.7.2. Before starting Work, protect any trees or shrubs shown or designated to be saved by boxing or wire fencing staked securely in place or other approved means, maintained until completion of work, or until removal may be directed by the Owner and the Engineer.
- 2.2.1.7.3. The Owner and Engineer shall be notified immediately if any unexpected subsurface condition, such as buried structures or utility lines are encountered, and discontinue work in that area until notified to proceed. The Engineer will determine the disposition of the obstruction. The Contractor shall adequately protect and support the obstruction until a determination is made and relocate, realign or dispose of the obstruction as directed by the Engineer at no additional cost to the Owner.
- 2.2.1.7.4. Protect the bottom of excavations and soil adjacent to and beneath foundations from frost.
- 2.2.1.7.5. The top of the excavation shall be mounded or graded to prevent surface water runoff from entering the excavation.
- 2.2.1.7.6. Erect and maintain guide rails, fences, warning lights or other protection as required for the safety of all persons at the excavations.

#### 2.2.2. Part 2 – Products

- 2.2.2.1. Topsoil: excavated material, graded free of roots, rocks larger than one inch (1”), subsoil, debris, weeds and foreign matter.
- 2.2.2.2. Subsoil: excavated material, graded free of lumps larger than six inches (6”), rocks larger than three inches (3”) and debris.
- 2.2.2.3. Rock: any material which cannot be dislodged by a D-8 Caterpillar tractor, or equivalent, equipped with a hydraulically operated power ripper (or by a CAT 235 hydraulic backhoe or equivalent) without the use of extraordinary rock excavation techniques. Boulders or masses of rock exceeding one half (1/2) cubic yard in volume shall also be considered rock excavation. This classification does not include materials such as loose rock, concrete or other materials that can be removed by means other than extraordinary rock excavation techniques, but which for reasons

**SECTION THREE  
TECHNICAL SPECIFICATIONS**

---

of economy in excavating the Contractor chooses to remove by extraordinary rock excavation techniques.

- 2.2.2.4. Buried Structures: concrete and masonry structures not shown on the drawings and encountered during the excavation and requiring removal shall be classified as rock.
- 2.2.2.5. Blasting Materials: explosive, delay devices, blasting mats and other associated materials shall be the type recommended by the explosives firm and as required by the authorities having jurisdiction.
- 2.2.2.6. Select Fill Materials:
  - 2.2.2.6.1. Type A - Crushed Stone: natural stone free of shale, clay, friable materials, debris and organic materials size and grading to comply with AASHTO No. 57.
  - 2.2.2.6.2. Type B - Crushed Stone: one half inch (½”) screenings - natural stone free of clay, shale, friable material, and debris.
  - 2.2.2.6.3. Type C - Sand: natural river or bank sand, washed, free of silt, clay, loam, friable or soluble materials and organic matter graded in accordance with ANSI/ASTM C136 within the following limits:

<u>Sieve Size</u>	<u>Total Percent Passing</u>
#4	100
14	60-100
50	20-80
100	10-30
200	0
- 2.2.2.7. Common Fill Materials - subsoil; either reused or imported soil material free of lumps larger than six inches (6”), rocks larger than two inches (2”), roots, organic material and debris.
- 2.2.2.8. Accessories:
  - 2.2.2.8.1. Silt Barrier Fence - PennDOT Class 3, Type B.
  - 2.2.2.8.2. Separation Fabric - PennDOT Class 4.

**SECTION THREE**  
**TECHNICAL SPECIFICATIONS**

---

2.2.3. Part 3 – Execution

2.2.3.1. Clearing and Grubbing.

- 2.2.3.1.1. Clear and grub all areas required for access to the site and execution of the Work. Remove all trees and shrubs within the marked areas designated for removal.
- 2.2.3.1.2. Protect all trees and shrubs designated to be maintained or relocated.
- 2.2.3.1.3. Grub out all stumps and roots to a minimum of three feet (3') below finished grade. Clear undergrowth and dead wood without disturbing the subsoil.
- 2.2.3.1.4. Remove and dispose of all perishable and objectionable material including but not limited to trees, brush, vines, shrubs, bushes, logs, stumps, roots, weeds, rubbish and other organic material.
- 2.2.3.1.5. Trees in rights-of-way shall not be cut down except by authorization of the Engineer. Excavation by hand, or tunneling may be required in vicinity of trees left standing.

2.2.3.2. Stair Removal.

- 2.2.3.2.1. Remove all existing stair construction within the lines of excavation.
- 2.2.3.2.2. All debris and material resulting from the removal shall be removed from the site and legally disposed of by the Contractor.

2.2.3.3. Preparation.

- 2.2.3.3.1. Identify required lines, levels, contours and datum.
- 2.2.3.3.2. Identify all utilities and mark locations.
- 2.2.3.3.3. Maintain and protect existing utilities which pass through the work area and are to remain in service.
- 2.2.3.3.4. Notify utility companies to remove and/or relocate utilities as required.

**SECTION THREE**  
**TECHNICAL SPECIFICATIONS**

---

- 2.2.3.3.5. Upon discovery of unknown utilities or concealed conditions, discontinue Work in the affected area and notify the Engineer.
- 2.2.3.3.6. Implement all procedures as required by the sediment and erosion control plan. Temporary seeding shall be employed on all areas that are disturbed and remain exposed for more than twenty (20) days.
- 2.2.3.4. Striping Topsoil.
  - 2.2.3.4.1. Before starting excavation, remove topsoil to its full depth, from all areas that are to be further excavated, relandscaped or regraded. Do not excavate saturated topsoil.
  - 2.2.3.4.2. Topsoil shall be stockpiled at the site as directed for use in further finish grading. All stockpiles shall receive temporary seeding.
- 2.2.3.5. Stockpiling.
  - 2.2.3.5.1. Stockpile materials on site at suitable locations, or as directed by the Engineer.
  - 2.2.3.5.2. Stockpile in sufficient quantities to meet Project schedule and requirements.
  - 2.2.3.5.3. Separate differing materials with dividers or stockpile apart to prevent mixing.
  - 2.2.3.5.4. Direct surface water away from stockpile site so as to prevent erosion or deterioration of materials.
  - 2.2.3.5.5. Clean stockpile area of excess fill material. Leave area in a clean and neat condition. Grade site surface to prevent free standing surface water.
- 2.2.3.6. Rock Excavation.
  - 2.2.3.6.1. If bedrock is encountered the Contractor shall immediately contact the Engineer and Owner to review the conditions.
  - 2.2.3.6.2. It is not intended to remove bedrock for the placement of footing piers for the stair construction. Should bedrock be encountered the Contractor shall provide three (3) #4 reinforcing bar dowels for

**SECTION THREE**  
**TECHNICAL SPECIFICATIONS**

---

imbedding into the bedrock. The Contractor shall drill holes to a minimum depth of six inch (6") for the insertion of the dowels prior to the placement of the concrete footings.

2.2.3.7. Excavation.

- 2.2.3.7.1. The Contractor shall perform all excavation required to construct all facilities, structures and Work incidental thereto. Excavation shall extend a sufficient distance to allow working space and inspection, except where concrete is to be deposited directly against excavated surfaces.
- 2.2.3.7.2. All loose material shall be removed from excavations, and bottoms shall be carefully leveled to grade.
- 2.2.3.7.3. None of the above provisions shall be construed to relieve the Contractor of his responsibility to make a careful personal examination of the site in order to satisfy himself as to the nature and location of the Work required, the conformation of the ground, the soil and rock conditions and the character, quality, and quantity of the materials.
- 2.2.3.7.4. Excavated materials to be used for backfill or other purposes shall be piled away from the edge of the excavated area a sufficient distance to prevent overloading the bank, and graded in such a way as to prevent surface water from entering the excavated area. Excess material from excavation not suitable or required for backfill or other purposes shall be hauled from the site.
- 2.2.3.7.5. Excavations shall not be carried below existing structure foundations or roadways.
- 2.2.3.7.6. Do not excavate to full depth when rain or freezing conditions are imminent. Where soil surfaces are damaged by water, mud, or otherwise disturbed, all loose mud or other materials shall be removed and the surface regraded.
- 2.2.3.7.7. The Contractor shall furnish adequate advance notification to the Engineer of times when footing excavations are to be completed so that the bearing quality of bottoms may be inspected and/or tested before forms are constructed or concrete placed.

### SECTION THREE TECHNICAL SPECIFICATIONS

---

- 2.2.3.7.8. Should the bearing at the levels indicated be found by the Engineer to be inadequate, they may order the excavation carried down to sound bearing.
- 2.2.3.7.9. The Contractor shall pump or otherwise remove any water which may be found in the excavation, and he shall provide drainage ditches, underdrains, flumes, well points, pumping equipment or other materials as necessary to keep the excavation free of water so that all required Work can be done in the dry. Except where the dewatering of the Work is specifically paid by unit price, this task shall be considered part of the prices bid and the Contractor will not receive additional compensation for dewatering.
- 2.2.3.8. Filling, Backfilling, and Rough Grading.
- 2.2.3.8.1. Filling and backfilling shall be performed to the rough grades as indicated in the plans.
- 2.2.3.8.2. The fill or backfill material shall be maintained at plus three percent (+3%) of the optimum moisture content, as determined by laboratory testing, to insure proper compaction.
- 2.2.3.8.3. No backfill shall be placed on frozen, wet, spongy or unstable subgrade surface. No frozen material shall be used for fill.
- 2.2.3.8.4. The Contractor shall employ a placement method to avoid damage to footings/foundations.
- 2.2.3.8.5. All areas disturbed during construction shall be rough graded to the elevations as indicated on the Drawings (+1 inch). Slope grade away from the building a minimum of two inches (2") in ten feet (10') unless noted otherwise on the Drawings. Changes in grade shall be gradual and slopes shall be blended into level areas.
- 2.2.3.8.6. Clean stockpile areas of excess fill material and remove surplus from the site. Any paved area (new or existing) over which hauling operations or other equipment moving is or was conducted shall be kept clean and any soil or other material left on paved surfaces shall be promptly removed by the Contractor.
- 2.2.3.8.7. Any areas damaged or disturbed during the course of the Work shall be restored to their original condition as directed by the Engineer.
-

**SECTION THREE**  
**TECHNICAL SPECIFICATIONS**

---

2.3. Section 02270 – Erosion and Sedimentation Control

2.3.1. Part 1 - General

2.3.1.1. Work Included.

2.3.1.1.1. Work required by regulations to prevent soil erosion and sedimentation.

2.3.1.2. Regulatory Requirements.

2.3.1.2.1. The erosion and sedimentation control measures are subject to inspection by State, County, and local regulatory agencies. The Contractor shall be fully responsible for constructing and maintaining erosion and sedimentation control measures to the extent that they are, at all times, acceptable to the regulatory agencies. The Contractor shall be liable for payment of any fines or legal costs that the Owner may incur as a result of the Contractor's failure to properly construct and maintain erosion and sedimentation control measures.

2.3.1.3. References

2.3.1.3.1. PennDOT Specifications, Publication 408.

2.3.2. Part 2 - Products

2.3.2.1. Materials

2.3.2.1.1. Rock for rip rap and ditch lining: PennDOT Section 850.

2.3.2.1.2. Coarse aggregates: PennDOT Section 703.2.

2.3.2.1.3. Filter fabric fence: PennDOT Section 865.2.

2.3.2.1.4. Geotextile fabric for rip rap and ditch lining: PennDOT Section 735, Class 2, Type A.

2.3.2.1.5. Seed, fertilizer, mulch, and erosion blankets: Section 02930 of these Specifications.

2.3.2.1.6. Selected material surfacing: PennDOT Section 703.3.

**SECTION THREE**  
**TECHNICAL SPECIFICATIONS**

---

2.3.2.1.7. Sand: PennDOT Section 703.1, cement concrete sand, Type A.

2.3.2.1.8. Synthetic Ditch Lining Material: Mirafi Miramat.

2.3.3. Part 3 - Execution

2.3.3.1. Construction Sequence.

2.3.3.1.1. Install all erosion and sedimentation control measures prior to start of clearing and earthwork operations.

2.3.3.1.2. Conduct construction operations in accordance with the following general sequence:

2.3.3.1.2.1. Construction of erosion and sedimentation control measures including ditches and swales, filter fabric fence, stabilized construction roads, and sedimentation basins as shown on the drawings.

2.3.3.1.2.2. Clearing, removal of debris, and stockpiling of soil materials.

2.3.3.1.2.3. Excavation.

2.3.3.1.2.4. Construction of stairs as noted on the plans.

2.3.3.1.2.5. Backfilling, final grading, paving, seeding, and other ground stabilization.

2.3.3.1.2.6. Removal of temporary erosion and sedimentation control measures.

2.3.3.2. Execution

2.3.3.2.1. Install filter fabric fences.

2.3.3.2.2. Place excavated material on the high side of the excavation, whenever possible, and confine the material so that it will not obstruct the normal flow in drainage courses.

2.3.3.2.3. The Contractor shall be responsible for the proper construction, stabilization and maintenance of all erosion and sedimentation pollution controls and related items within the Plan.



## SECTION THREE TECHNICAL SPECIFICATIONS

---

- 2.3.3.2.4. Should any measures contained within the Plan be incapable of either adequately removing sediment from on-site flows prior to discharge from the site or stabilizing the surfaces involved, additional measures shall be immediately implemented by the Contractor to eliminate all such problems.
- 2.3.3.2.5. If a sinkhole develops during construction, the Contractor shall immediately contact the Owner and Engineer.
- 2.3.3.2.6. Should unforeseen erosive conditions develop during construction, the Contractor shall take action to remedy such conditions and to prevent damage to adjacent properties as a result of increased runoff and/or sediment displacement. Stockpiles of wood chips, hay bales, crushed stone and other mulches shall be held in readiness to deal immediately with emergency problems of erosion
- 2.3.3.2.7. The Contractor is advised to become thoroughly familiar with the provisions of Appendix 64, Erosion Control Rules and Regulations, Title 25, Part 1, Department of Environmental Protection, Sub-Part C, Protection of Natural Resources, Article III, Water Resources, Chapter 102, Erosion Control.

### 2.3.3.3. Restoration

- 2.3.3.3.1. After completion of construction, remove all temporary erosion and sedimentation control devices. Restore areas in which these devices were located to the original condition or to the condition called for by the Contract Documents.

## 2.4. Section 03300 - Cast-In-Place Concrete

### 2.4.1. Part 1 - General

#### 2.4.1.1. Section Includes:

- 2.4.1.1.1. Formwork, complete with shoring, bracing and anchorage.
- 2.4.1.1.2. Cast-in-place concrete.
- 2.4.1.1.3. Reinforcing steel, welded wire fabric, supports, spacers and accessories.

**SECTION THREE**  
**TECHNICAL SPECIFICATIONS**

---

- 2.4.1.1.4. Concrete Curing.
- 2.4.1.2 Work Installed But Furnished Under Other Sections.
  - 2.4.1.2.1. Section 06001 – Carpentry Work.
- 2.4.1.3. References.
  - 2.4.1.3.1. ACI 117 – Specifications for Tolerances for Concrete Construction and Materials.
  - 2.4.1.3.2. ACI 301 - Specifications for Structural Concrete for Buildings.
  - 2.4.1.3.3. ACI 305R - Hot Weather Concreting.
  - 2.4.1.3.4. ACI 306R - Cold Weather Concreting.
  - 2.4.1.3.5. ACI 308 - Standard Practice for Curing Concrete.
  - 2.4.1.3.6. ACI 318 - Building Code Requirements for Reinforced Concrete.
  - 2.4.1.3.7. ACI 350 – Environmental Engineering Structures.
  - 2.4.1.3.8. ANSI/ASTM A185 - Welded Steel Wire Fabric for Concrete Reinforcement.
  - 2.4.1.3.9. ANSI/ASTM A497 - Welded Deformed Steel Wire Fabric for Concrete Reinforcement.
  - 2.4.1.3.10. ASTM A615 - Deformed and Plain Billet-Steel for Concrete Reinforcement.
  - 2.4.1.3.11. ASTM C33 - Concrete Aggregates.
  - 2.4.1.3.12. ASTM C94 - Ready-Mixed Concrete.
  - 2.4.1.3.13. ASTM C150 - Portland Cement.
  - 2.4.1.3.14. ASTM C260 - Air-Entraining Admixtures for Concrete.
  - 2.4.1.3.15. ASTM C309 - Liquid Membrane - Forming Compounds for Curing Concrete.

**SECTION THREE**  
**TECHNICAL SPECIFICATIONS**

---

- 2.4.1.3.16. ASTM C494 - Chemical Admixtures for Concrete.
- 2.4.1.3.17. ASTM D 1752 - Preformed Sponge Rubber and Cork Expansion Joint Fillers for Concrete Paving and Structural Construction.
- 2.4.1.3.18. ASTM D2103 - Polyethylene Film and Sheeting.
- 2.4.1.4. Quality Assurance.
  - 2.4.1.4.1. Perform work in accordance with ACI 301.
  - 2.4.1.4.2. Maintain copy of ACI 301 on site.
  - 2.4.1.4.3. Obtain materials (including cementitious material, aggregate, admixture, etc.) from same source throughout the Work.
  - 2.4.1.4.4. Work shall be performed by an experienced installer who has completed concrete work similar in material, design, and extent to that indicated for this Project and whose work has resulted in construction with a record of successful in-service performance.
  - 2.4.1.4.5. Obtain concrete from a firm experienced in manufacturing ready-mixed concrete products complying with ASTM C94 requirements for production facilities and equipment.
- 2.4.1.5. Regulatory Requirements.
  - 2.4.1.5.1. Conform to applicable building code for area where Project is located.
- 2.4.1.6. Submittals
  - 2.4.1.6.1. Proposed concrete mix design for each class of concrete along with sufficient data to document the proportioning of the proposed concrete mix in accordance with ACI 301.
  - 2.4.1.6.2. Proposed curing methods for hot and cold weather.
- 2.4.1.7. Tests
  - 2.4.1.7.1. Testing and analysis of concrete shall be performed by an independent testing agency engaged and paid for by the Contractor

### SECTION THREE TECHNICAL SPECIFICATIONS

---

and approved by the Engineer. Testing shall be performed in accordance with Section 01400 – Quality Control.

- 2.4.1.7.2. Submit proposed mix design to Engineer for review prior to commencement of work.
- 2.4.1.7.3. Testing firm shall take cylinders and perform slump and air entrainment tests in accordance with ACI 301.
- 2.4.1.7.4. Four (4) concrete test cylinders shall be taken for every fifty (50) or less cubic yards of concrete placed each day as directed by the Engineer.
- 2.4.1.7.5. Two (2) additional test cylinders shall be taken during cold weather and cured on site under same conditions as concrete they represent.
- 2.4.1.7.6. One (1) slump test shall be taken for each set of test cylinders taken.

#### 2.4.2. Part 2 - Products

##### 2.4.2.1. Concrete Materials (ACI 301 2.1)

- 2.4.2.1.1. Cement: ASTM C150, moderate - Type II Portland type; grey color.
- 2.4.2.1.2. Fine and Coarse Aggregates: Normal-weight aggregate conforming to ASTM C33, uniformly graded, subject to limitations of ACI 301 3.6.
  - 2.4.2.1.2.1. Class: Moderate weathering region, but not less than 3M.
  - 2.4.2.1.2.2. Nominal Maximum Aggregate Size: one and one-half inches (1-1/2”).
- 2.4.2.1.3. Water: Potable, clean and not detrimental to concrete.
- 2.4.2.1.4. All cast-in-place concrete shall be ready-mixed type material. The use of bag type mixes is not allowed.
- 2.4.2.1.5. Obtain materials from same source throughout project.

**SECTION THREE**  
**TECHNICAL SPECIFICATIONS**

---

- 2.4.2.1.6. Maintain uniform coloration of finished product.
- 2.4.2.2. Concrete Mixes
  - 2.4.2.2.1. Prepare design mixes for each type and strength of concrete determined by either laboratory trial mix or field test data bases, as follows:
    - 2.4.2.2.1.1. Proportion normal-weight concrete according to ACI 211.1 and ACI 301.
  - 2.4.2.2.2. Use a qualified independent testing agency for preparing and reporting proposed mix designs for the laboratory trial mix basis.
  - 2.4.2.2.3. Footings and Foundations: Proportion normal-weight concrete mix as follows:
    - 2.4.2.2.3.1. Compressive Strength (twenty-eight (28) days): four thousand pounds per square inch (4000 psi).
    - 2.4.2.2.3.2. Maximum Slump: four inches (4”).
    - 2.4.2.2.3.3. Maximum Water – Cementitious Material Ratio: 0.45.
  - 2.4.2.2.4. Cementitious Materials:
    - 2.4.2.2.4.1. Minimum Cementitious Materials Content: four hundred seventy pounds per cubic yard (470 lb/cy).
  - 2.4.2.2.5. Air Content: Add air-entraining admixture at manufacturer’s prescribed rate to result in concrete at point of placement having an air content as follows within a tolerance of plus one percent (1%) or minus one and one-half percent (1.5%), unless otherwise indicated:
    - 2.4.2.2.5.1. Air Content: Five and one-half percent (5.5%) for one and one-half inch (1 ½”) nominal maximum aggregate size.
- 2.4.2.3. Reinforcing Steel (ACI 301 5.2) and Accessories.
  - 2.4.2.3.1. Reinforcing Steel: ASTM A775, including Supplementary Requirements S1, sixty (60) ksi yield grade billet steel deformed bars.

**SECTION THREE**  
**TECHNICAL SPECIFICATIONS**

---

2.4.2.3.2. Plain-Steel Wire: ASTM A82, as drawn.

2.4.2.4. Curing Materials

2.4.2.4.1. Evaporation Retarder: Waterborn, monomolecular film forming, manufactured for application to fresh concrete: ASTM.

2.4.2.4.1.1. Acceptable Manufacturers:

2.4.2.4.1.1.1. L&M Construction Chemicals, Inc. - E-Con

2.4.2.4.1.1.2. Or approved equal.

2.4.2.4.2. Absorptive Cover: AASHTO M 182, Class 2, burlap cloth made from jute or kenaf, weighing approximately nine (9) oz./sq. yd. dry.

2.4.2.4.3. Moisture-Retaining Cover: ASTM C 171, polyethylene film or white burlap polyethylene sheet.

2.4.2.4.4. Water: Potable.

2.4.3. Part 3 - Execution

2.4.3.1. General.

2.4.3.1.1. Install concrete work and compounds in accordance with ACI 301, 302, 302.1R, 304, 305, 306, and 308; and the manufacturer's instructions.

2.4.3.2. Formwork (ACI 301 4.2).

2.4.3.2.1. Verify lines, levels and measurements before proceeding with formwork.

2.4.3.2.2. Earth forms are permitted on this project.

2.4.3.2.3. Design, erect, shore, brace, and maintain formwork for footings above grade level, according to ACI 301, to support vertical, lateral, static, and dynamic loads, and construction loads that might be applied, until concrete structure can support such loads.

**SECTION THREE**  
**TECHNICAL SPECIFICATIONS**

---

- 2.4.3.2.4. Construct formwork so concrete members and structures are of size, shape, alignment, elevation, and position indicated, within tolerance limits of ACI 117.
- 2.4.3.2.5. Limit concrete surface irregularities, designated by ACI 347R as abrupt or gradual, as follows:
  - 2.4.3.2.5.1. Class A, one-eighth inch (1/8") for concrete surfaces exposed to view.
  - 2.4.3.2.5.2. Class C, one-half inch (1/2") for remaining concrete surfaces.
- 2.4.3.2.6. Construct forms tight enough to prevent loss of concrete mortar.
- 2.4.3.2.7. Fabricate forms for easy removal without hammering or prying against concrete surfaces. Provide crush or wrecking plates where stripping may damage cast concrete surfaces. Provide top forms for inclined surfaces steeper than 1.5 horizontal to 1 vertical. Kerf wood inserts for forming keyways, reglets, recesses, and the like, for easy removal.
  - 2.4.3.2.7.1. Do not use rust-stained steel form facing material.
- 2.4.3.3. Form Surfaces Preparation (ACI 301 4.4).
  - 2.4.3.3.1. Clean forms and adjacent surfaces to receive concrete. Remove chips, wood, sawdust, dirt and other debris just before placing concrete.
  - 2.4.3.3.2. Apply form release agent on formwork in accordance with manufacturer's recommendations. Apply prior to placing reinforcing steel, anchoring devices and embedded parts. Do not apply form release agent where concrete surfaces will receive special finishes or applied coverings which are affected by agent.
- 2.4.3.4. Reinforcing Steel (ACI 301 5.1 to 5.5).
  - 2.4.3.4.1. No welding of reinforcing steel will be permitted unless approved in writing by the Engineer.
  - 2.4.3.4.2. No reinforcing steel embedded in hardened concrete shall be bent unless approved in writing by the Engineer.

**SECTION THREE**  
**TECHNICAL SPECIFICATIONS**

---

2.4.3.5. Control of Mixing Water (ACI 301 7.5.2).

- 2.4.3.5.1. No additional water shall be added to the concrete after it arrives at the job site unless authorized by the Engineer or his authorized representative. If additional water is added, additional cement must be added to maintain the original water-cement ratio specified herein.
- 2.4.3.5.2. Do not add water to concrete after adding high-range water-reducing admixtures to mix.

2.4.3.6. Placing Concrete

- 2.4.3.6.1. Conduct concrete placement following provisions of ACI 304 and these additional requirements.
- 2.4.3.6.2. Notify Engineer a minimum of twenty-four (24) hours (one full workday) prior to commencement of concreting operations.
  - 2.4.3.6.2.1. Do not schedule concrete placement when weather forecast includes precipitation, or unusually hot or unusually cold weather.
  - 2.4.3.6.2.2. Do not place concrete in precipitation, or unusually hot or unusually cold weather.
- 2.4.3.6.3. Prepare formwork in advance. Remove snow, ice, water and debris from within forms. Order sufficient ready-mixed material to ensure sufficient quantities are on hand to complete the concreting pour as scheduled without delays in delivery of last mixer vehicle.
- 2.4.3.6.4. Handle concrete from mixer to final deposit location rapidly by methods which will prevent segregation or loss of ingredients, to maintain required concrete quality.
- 2.4.3.6.5. Do not convey concrete through aluminum or aluminum alloy products.
- 2.4.3.6.6. Do not allow concrete to drop vertically more than four (4) feet. Deposit concrete in twelve to eighteen inch (12-18") horizontal layers. Continue placing concrete at a rate so that concrete being placed is being integrated with newly placed concrete, and all concrete is still plastic to avoid seams or planes of weakness.



### SECTION THREE TECHNICAL SPECIFICATIONS

---

Schedule delivery of concrete so that there are not pauses between placement operations.

2.4.3.6.7. Consolidate concrete by mechanical vibration. Work concrete around reinforcement, embedded items, and into all corners. Maintain reinforcement in position on chairs during concrete placement. Eliminate stones pockets and air pockets and other causes of honeycombing, pitting or other possible weakness.

2.4.3.6.8. Use concrete vibrators of internal type. Do not use vibration equipment attached to forms and reinforcement. Vibration equipment shall transmit vibration to concrete in frequencies sufficient to provide satisfactory consolidation. Do not position vibration equipment in one location long enough to cause segregation of material.

2.4.3.7. Removal and Reuse of Forms (ACI 301 4.5).

2.4.3.7.1. General: Formwork, for sides of footings and similar parts of the Work, that does not support weight of concrete may be removed after cumulatively curing at not less than fifty degrees (50°) Fahrenheit for twenty-four (24) hours after placing concrete provided concrete is hard enough to not be damaged by form-removal operations and provided curing and protection operations are maintained.

2.4.3.8. Repair or Replacement of Surface Defects (ACI 301 9.1).

2.4.3.8.1. Allow Engineer to inspect concrete surfaces immediately upon removal of forms.

2.4.3.8.2. Replace concrete not conforming to required lines, detail, elevations and tolerances. The costs of demolishing unacceptable concrete and its replacement by installing new reinforcement, forming and concrete placement shall be performed at the Contractor's cost.

2.4.3.8.3. Demolish and replace concrete not properly placed resulting in honeycombing and other defects. Do not patch, or repair exposed architectural concrete. Patching of honeycombed or significantly blemished concrete shall not be allowed.

**SECTION THREE**  
**TECHNICAL SPECIFICATIONS**

---

- 2.4.3.8.4. If strength tests fail to meet the requirements of ACI 301, Section 17.2, the Owner/Engineer may require in place and/or core tests in accordance with ACI 301, Section 17.3. Cost of all additional testing shall be paid by the Contractor.
- 2.4.3.8.5. Patching Mortar: Mix dry pack patching mortar, consisting of one part Portland cement to two and one half parts fine aggregate passing a No. 16 sieve, using only enough water for handling and placing.
- 2.4.3.8.6. Repairing Formed Surfaces: Surface defects include color and texture irregularities, cracks, spalls, air bubbles, rock pockets, fins and other projections on the surface, and stains and other discolorations that cannot be removed by cleaning.
  - 2.4.3.8.6.1. Immediately after form removal, fill and compact minor blemishes with patching mortar before bonding agent has dried. Fill form tie voids with patching mortar or cone plugs secured in place with bonding agent.
  - 2.4.3.8.6.2. Repair defects on surfaces exposed to view by blending white Portland cement and standard Portland cement so that, when dry, patching mortar will match surrounding color. Patch a test area at inconspicuous locations to verify mixture and color match before proceeding with patching. Compact mortar in place and strike off slightly higher than surrounding surface.
  - 2.4.3.8.6.3. Repair defects on concealed formed surfaces that affect concrete's durability and structural performance as determined by Engineer.
  - 2.4.3.8.6.4. No repair of honeycomb or significant blemishes shall be allowed. Complete demolition and replacement is required.
- 2.4.3.9. Schedule of Formed Surfaces.
  - 2.4.3.9.1. Rubbed Finish: Apply the following to smooth-formed finished concrete:
    - 2.4.3.9.1.1. Grout-Cleaned Finish: Wet concrete surfaces and apply grout of a consistency of thick paint to coat surfaces and fill small holes. Mix one part Portland cement to one (1) and one-half (1/2) parts fine sand with a 1:1 mixture of bonding admixture

### SECTION THREE TECHNICAL SPECIFICATIONS

---

and water. Add white Portland cement in amounts determined by trial patches so color of dry grout will match adjacent surfaces. Scrub grout into voids and remove excess grout. When grout whitens, rub surface with clean burlap and keep surface damp by fog spray for at least thirty-six (36) hours.

- 2.4.3.9.2. Related Unformed Surfaces: At tops of footings and similar unformed surfaces adjacent to formed surfaces, strike off smooth and finish with a texture matching adjacent formed surfaces. Continue final surface treatment of formed surfaces uniformly across adjacent unformed surfaces, unless otherwise indicated.
- 2.4.3.9.3. Repair form tie holes by hammer packing holes with stiff mortar with same mix and ingredients as in surrounding concrete. Remove fins and other projections exceeding ACI 347R limits for class of surface specified. Prepare mortar not more than thirty (30) minutes before use. All tie hole repairs shall be inconspicuous on completion.

#### 2.4.3.10. Protection (ACI 301, Chapter 12).

- 2.4.3.10.1. Protect finished work as required to prevent damage until cured.
- 2.4.3.10.2. Immediately after placement, protect concrete from premature drying, excessively hot or cold temperatures, and mechanical injury.
- 2.4.3.10.3. Maintain concrete with minimal moisture loss at relatively constant temperature for period necessary for hydration of cement and hardening of concrete, at least seven (7) days, except for high early strength which requires three (3) days.
- 2.4.3.10.4. Hot weather curing and cold weather curing procedures must be submitted by the Contractor for approval. Cold weather concreting shall follow ACI 306R. Hot weather concreting shall follow ACI 305R. No cold weather concreting will be allowed when the air temperature during placement is twenty-five degrees (25°) Fahrenheit or less. No hot weather concreting will be allowed when the air temperature during placement is ninety degrees (90°) Fahrenheit or higher. Concrete blankets and heating shall be provided during cold weather concreting. Cooling provisions shall be implemented during hot weather concreting.

**SECTION THREE**  
**TECHNICAL SPECIFICATIONS**

---

- 2.4.3.10.5. Evaporation Retarder: Apply evaporation retarder to unformed concrete surfaces if hot, dry, or windy conditions cause moisture loss approaching 0.2 lb/sq. ft. x h before and during finishing operations. Apply according to manufacturer's written instructions after placing, screeding, and bull floating or darbying concrete, but before float finishing.
- 2.4.3.10.6. Curing Methods: Cure concrete by curing compound, by moist curing, by moisture-retaining cover curing, or by combining these methods, as specified.
  - 2.4.3.10.6.1. Formed Surfaces: If nonabsorbent forms are left in place for seven days, no curing is necessary. Moist cure if absorbent forms are used. Cover cure or cure by curing compound if forms are removed prior to seven days.

3. DIVISION 5 – METALS

3.1. Section 05500 - Miscellaneous Metals.

3.1.1. Part 1 – General.

3.1.1.1. Section Includes:

- 3.1.1.1.1. Included under this Section is the furnishing and installation of all items of miscellaneous steel and metal fabrication, or other work listed, included, but not limited to, below and/or as detailed on the Drawings.

3.1.1.2. Items Include:

- 3.1.1.2.1. Loose bearing and leveling plates.
- 3.1.1.2.2. Aluminum pipe railing.
- 3.1.1.2.3. Miscellaneous framing and supports.
- 3.1.1.2.4. Miscellaneous metal trim.

## SECTION THREE TECHNICAL SPECIFICATIONS

---

### 3.1.1.3. References.

3.1.1.3.1. Workmanship and materials shall conform to the latest revision of the following standards hereafter referred to by acronym or alpha/numeric designation only:

- 3.1.1.3.1.1. ASTM A36: Structural Steel.
- 3.1.1.3.1.2. ASTM A53: Gr. B: Pipe, Steel, Black and Hot-dipped, Zinc-coated Welded and Seamless Steel Pipe.
- 3.1.1.3.1.3. ASTM A123: Zinc Hot-Dipped (Galvanized) Coating on Iron and Steel Products.
- 3.1.1.3.1.4. ASTM A153: Zinc Coating (Hot-Dip) on Iron and Steel Hardware.
- 3.1.1.3.1.5. ASTM A307: Carbon Steel Bolts and Studs, 60,000 psi Tensile Strength.
- 3.1.1.3.1.6. ASTM A386: Practice for Providing High Quality Zinc Hot-Dipped (Galvanized) Coating on Iron and Steel Products.
- 3.1.1.3.1.7. ASTM A501: Hot-formed Welded and Seamless Carbon Steel Structural Steel Tubing.
- 3.1.1.3.1.8. AISC: American Institute of Steel Construction - Specification for Structural Steel Buildings Allowable Stress Design and Plastic Design.
- 3.1.1.3.1.9. AWS: American Welding Society – All applicable specifications listed in AISC above.
- 3.1.1.3.1.10. NAAMM: National Association of Architectural Metal Manufacturers' Standard Specifications for Metal Bar Grating.
- 3.1.1.3.1.11. AASHTO: American Association of State Highway and Transportation Officials.

### 3.1.1.4. Construction Submittals.

3.1.1.4.1. The Contractor shall prepare and submit complete shop and erection drawings for approval prior to fabrication. Include plans,

---

## SECTION THREE TECHNICAL SPECIFICATIONS

---

elevations, sections and details of metal fabrications and their connections. Show anchorage and accessory items.

- 3.1.1.4.1.1. Provide templates for anchors and bolts specified for installation.
- 3.1.1.4.2. The Shop Drawings shall show all light iron and miscellaneous metal dimensions, details of construction, details of installation, relation to adjoining work, reinforcement, welds, fastenings, anchorage, specifications of shop finishes and other items as required or specified in order that a proper evaluation can be provided.
- 3.1.1.5. Quality Assurance.
  - 3.1.1.5.1. Fabricator Qualifications: A firm experienced in producing metal fabrications similar to those indicated for this Project and with a record of successful in service performance, as well as sufficient production capacity to produce required units.
  - 3.1.1.5.2. Welding: Qualify procedures and personnel according to the following:
    - 3.1.1.5.2.1. AWS D1.1, “Structural Welding Code – Steel”.
    - 3.1.1.5.2.2. AWS D1.2, “Structural Welding Code – Aluminum”.
    - 3.1.1.5.2.3. AWS D1.3, “Structural Welding Code – Sheet Steel”.
    - 3.1.1.5.2.4. Certify that each welder has satisfactorily passed AWS qualification tests for welding processes involved and, if pertinent, has undergone re certification.
- 3.1.1.6. Project Coordinator.
  - 3.1.1.6.1. Field Measurements: Where metal fabrications are indicated to fit walls and other construction, verify dimensions by field measurements before fabrication and indicate measurements on Shop Drawings. Coordinate fabrication schedule with construction progress to avoid delaying the Work.

## SECTION THREE TECHNICAL SPECIFICATIONS

---

### 3.1.1.7. Coordination.

- 3.1.1.7.1. Coordinate installation of anchorages for metal fabrications. Furnish setting drawings, templates, and directions for installing anchorages, including sleeves, concrete inserts, anchor bolts, and items with integral anchors, that are to be embedded in concrete or masonry. Deliver such items to Project site in time for installation.

### 3.1.1.8. Delivery, Storage, and Handling.

- 3.1.1.8.1. All materials for the work of this Section shall be delivered, stored and handled so as to preclude damage of any nature. Manufactured materials shall be delivered and stored in their original containers, plainly marked with the product's and manufacturer's name. Materials in broken containers or in packages showing watermarks or other evidence of damage, shall not be used and shall be removed from the site.

### 3.1.2. Part 2 – Products.

#### 3.1.2.1. Metals, General.

- 3.1.2.1.1. Metal Surfaces, General: For metal fabrications exposed to view in the completed Work, provide materials with smooth, flat surfaces without blemishes. Do not use materials with exposed pitting, seam marks, roller marks, rolled trade names, or roughness.

#### 3.1.2.2. Ferrous Metals.

- 3.1.2.2.1. Steel Plates, Shapes, and Bars: ASTM A36/A 36M.
- 3.1.2.2.2. Welding Rods and Bare Electrodes: Select according to AWS specifications for metal alloy welded.

#### 3.1.2.3. Aluminum Metals.

- 3.1.2.3.1. Handrail Tubing - Schedule 80, high-tensile aluminum-magnesium alloy manufactured in compliance with ASTM B26.

## SECTION THREE TECHNICAL SPECIFICATIONS

---

### 3.1.2.4. Fasteners.

- 3.1.2.4.1. Bolts and Nuts: Regular hexagon-head bolts, ASTM A 307, Grade A; with hex nuts, ASTM A 563; and, where indicated, flat washers.
- 3.1.2.4.2. Anchor Bolts: ASTM F 1554, Grade 36.
- 3.1.2.4.3. Machine Screws: ASME B 18.6.3.
- 3.1.2.4.4. Expansion Anchors: Anchor bolt and sleeve assembly of material indicated below with capability to sustain, without failure, a load equal to six times the load imposed when installed in unit masonry and equal to four times the load imposed when installed in concrete, as determined by testing per ASTM E 488, conducted by a qualified independent testing agency.
  - 3.1.2.4.4.1. Material: Carbon-steel components zinc-plated to comply with ASTM B 633, Class Fe/Zn 5.
  - 3.1.2.4.4.2. Material: Alloy Group 1 or 2 stainless-steel bolts complying with ASTM F 593 and nuts complying with ASTM F 594.

### 3.1.2.5. Fabrication, General.

- 3.1.2.5.1. Shop Assembly: Preassemble items in shop to greatest extent possible to minimize field splicing and assembly. Disassemble units only as necessary for shipping and handling limitations. Use connections that maintain structural value of joined pieces. Clearly mark units for reassembly and coordinated installation.
- 3.1.2.5.2. Shear and punch metals cleanly and accurately. Remove burrs.
- 3.1.2.5.3. Ease exposed edges to a radius of approximately 1/32 inch, unless otherwise indicated. Form bent-metal corners to smallest radius possible without causing grain separation or otherwise impairing work.
- 3.1.2.5.4. Weld corners and seams continuously to comply with the following:
  - 3.1.2.5.4.1. Use materials and methods that minimize distortion and develop strength and corrosion resistance of base metals.



**SECTION THREE**  
**TECHNICAL SPECIFICATIONS**

---

- 3.1.2.5.4.2. Obtain fusion without undercut or overlap.
- 3.1.2.5.4.3. Remove welding flux immediately.
- 3.1.2.5.4.4. At exposed connections, finish exposed welds and surfaces smooth and blended so no roughness shows after finishing and contour of welded surface matches that of adjacent surface.
- 3.1.2.5.5. Provide for anchorage of type indicated; coordinate with supporting structure. Fabricate and space anchoring devices to secure metal fabrications rigidly in place and to support indicated loads.
- 3.1.2.5.6. Cut, reinforce, drill, and tap metal fabrications as indicated to receive finish hardware, screws, and similar items.
- 3.1.2.5.7. Fabricate joints that will be exposed to weather in a manner to exclude water, or provide weep holes where water may accumulate.
- 3.1.2.5.8. Form exposed work true to line and level with accurate angles and surfaces and straight sharp edges.
- 3.1.2.5.9. Remove sharp or rough areas on exposed traffic surfaces.
- 3.1.2.5.10. Form exposed connections with hairline joints, flush and smooth, using concealed fasteners where possible. Use exposed fasteners of type indicated or, if not indicated, Phillips flathead (countersunk) screws or bolts. Locate joints where least conspicuous.
- 3.1.2.6. Loose Bearing and Leveling Plates.
  - 3.1.2.6.1. Provide loose bearing and leveling plates for steel items bearing on masonry or concrete construction. Drill plates to receive anchor bolts and for grouting.
  - 3.1.2.6.2. Galvanize plates after fabrication.

**SECTION THREE**  
**TECHNICAL SPECIFICATIONS**

---

3.1.2.7. Aluminum Pipe Railing.

- 3.1.2.7.1. Fabricate railings from one and one-half inch (1-1/2") diameter, schedule 80, high-tensile aluminum-magnesium alloy manufactured in compliance with ASTM B26, as manufactured by Hollaender Manufacturing Co. or approved equal.
- 3.1.2.7.2. Use flush all welded construction and welds ground smooth. Secure rails to stair framing with brackets as noted. Fit exposed end of rails with screw plug finial.
- 3.1.2.7.3. See notes of Drawings for information on railing brackets.

3.1.2.8. Miscellaneous Framing and Supports.

- 3.1.2.8.1. General: Provide steel framing and supports indicated and as necessary to complete the Work.
- 3.1.2.8.2. Fabricate units from structural-steel shapes, plates, and bars of welded construction, unless otherwise indicated. Fabricate to sizes, shapes, and profiles indicated and as necessary to receive adjacent construction retained by framing and supports. Cut, drill, and tap units to receive hardware, hangers, and similar items.
  - 3.1.2.8.2.1. Where units are indicated to be cast into concrete or built into masonry, equip with integrally welded steel strap anchors one and one-quarter inch (1 1/4") wide by one-quarter inch (1/4") thick by eight inches (8") long at twenty-four inches (24") on center, unless otherwise indicated.
- 3.1.2.8.3. Fabricate supports for overhead doors as required for proper track installation. Brace support framing as required to prevent movement of door track.
- 3.1.2.8.4. Galvanize miscellaneous framing and supports.

3.1.2.9. Miscellaneous Metal Trim.

- 3.1.2.9.1. Unless otherwise indicated, fabricate units from structural-steel shapes, plates, and bars of profiles shown with continuously welded joints, and smooth exposed edges. Miter corners and use concealed field splices where possible.

**SECTION THREE**  
**TECHNICAL SPECIFICATIONS**

---

3.1.2.9.2. Provide cutouts, fittings, and anchorages as needed to coordinate assembly and installation with other work. Provide anchors, welded to trim, for embedding in concrete or masonry construction, spaced not more than six inches (6”) from each end, six inches (6”) from corners, and twenty-four inches (24”) on center, unless otherwise indicated.

3.1.2.9.3. Galvanize all miscellaneous steel trim.

3.1.2.10. Finishes, General.

3.1.2.10.1. Comply with NAAMM’s “Metal Finishes Manual for Architectural and Metal Products” for recommendations for applying and designating finishes.

3.1.2.10.2. Finish metal fabrications after assembly.

3.1.2.10.3. Aluminum tubing for handrails to be mill finish.

3.1.2.10.4. Finish of railing brackets to be per manufacturer’s standard finish for the type of bracket specified.

3.1.3. Part 3 – Execution.

3.1.3.1. Protection.

3.1.3.1.1. Protect existing adjacent construction from damage during work performed in this Section.

3.1.3.2. Workmanship.

3.1.3.2.1. Metal surfaces shall be clean and free from mill scale, flake rust and rust pitting; well-formed and finished to shape and size, with sharp lines and angles and smooth surfaces. Shearing and punching shall leave clean true lines and surfaces. Weld or rivet permanent connections. Welds and flush rivets shall be finished flush and smooth on surfaces that will be exposed after installation. Do not use screws or bolts where they can be avoided; where used, heads shall be countersunk, screwed up tight and threads nicked to prevent loosening.

3.1.3.2.2. Fastenings shall be concealed where practicable. Thickness of metal and details of assembly and supports shall give ample

## SECTION THREE TECHNICAL SPECIFICATIONS

---

strength and stiffness. Joints exposed to weather shall be formed to exclude water. Provide holes and connections for the work of other trades.

3.1.3.2.3. At proper time, deliver and set in place items of metal work to be built into adjoining construction.

3.1.3.2.4. All stair work shall be accurately set to establish lines and elevations and rigidly fastened in place with suitable attachments to the construction of the building. At the completion of the work, all work shall be checked over, readjusted, and left in workmanlike condition. All welds exposed to view shall be ground smooth to the touch.

### 3.1.3.3. Painting and Protective Coating.

3.1.3.3.1. All ferrous metal, except stainless steel and galvanized surfaces, shall be properly cleaned and given one shop coat of primer to match structural steel primer. Anchors that are built into masonry shall be coated with asphalt paint unless specified to be galvanized. Metal work to be encased in concrete shall be left unpainted unless specified or noted otherwise. Where hot-dipped galvanized or zinc-coated metal is specified or shown, it shall not be shop primed unless specifically required.

3.1.3.3.2. All aluminum shall be isolated from contact with concrete and from dissimilar metals with bituminous paint.

### 3.1.3.4. Installation, General.

3.1.3.4.1. Fastening to In Place Construction: Provide anchorage devices and fasteners where necessary for securing metal fabrications to in place construction. Include threaded fasteners for concrete and masonry inserts, toggle bolts, through bolts, lag bolts, wood screws, and other connectors.

3.1.3.4.2. Cutting, Fitting, and Placement: Perform cutting, drilling, and fitting required for installing metal fabrications. Set metal fabrications accurately in location, alignment, and elevation; with edges and surfaces level, plumb, true, and free of rack; and measured from established lines and levels.

**SECTION THREE**  
**TECHNICAL SPECIFICATIONS**

---

- 3.1.3.4.3. Provide temporary bracing or anchors in formwork for items that are to be built into concrete, masonry, or similar construction.
- 3.1.3.4.4. Fit exposed connections accurately together to form hairline joints. Weld connections that are not to be left as exposed joints but cannot be shop welded because of shipping size limitations. Do not weld, cut, or abrade surfaces of exterior units that have been hot dip galvanized after fabrication and are for bolted or screwed field connections.
- 3.1.3.4.5. Field Welding: Comply with the following requirements:
  - 3.1.3.4.5.1. Use materials and methods that minimize distortion and develop strength and corrosion resistance of base metals.
  - 3.1.3.4.5.2. Obtain fusion without undercut or overlap.
  - 3.1.3.4.5.3. Remove welding flux immediately.
  - 3.1.3.4.5.4. At exposed connections, finish exposed welds and surfaces smooth and blended so no roughness shows after finishing and contour of welded surface matches that of adjacent surface.
- 3.1.3.5. Setting, Bearing, and Leveling Plates.
  - 3.1.3.5.1. Clean concrete and masonry bearing surfaces of bond-reducing materials, and roughen to improve bond to surfaces. Clean bottom surface of plates.
  - 3.1.3.5.2. Set bearing and leveling plates on wedges, shims, or leveling nuts. After bearing members have been positioned and plumbed, tighten anchor bolts. Do not remove wedges or shims but, if protruding, cut off flush with edge of bearing plate before packing with grout.
  - 3.1.3.5.3. Pack grout solidly between bearing surfaces and plates to ensure that no voids remain.
- 3.1.3.6. Installing Miscellaneous Framing and Supports.
  - 3.1.3.6.1. General: Install framing and supports to comply with requirements of items being supported, including manufacturers' written instructions and requirements indicated on Shop Drawings, if any.

**SECTION THREE**  
**TECHNICAL SPECIFICATIONS**

---

- 3.1.3.6.2. Anchor supports for overhead door tracks securely to and rigidly brace from building structure.
- 3.1.3.6.3. Install pipe columns on concrete footings with grouted baseplates. Position and grout column baseplates as specified above for setting and grouting bearing and leveling plates.

**4. DIVISION 6 - WOOD AND PLASTIC**

4.1. Section 06001 – Carpentry Work.

4.1.1. Part 1 – General.

4.1.1.1. Work Included.

- 4.1.1.1.1. Rough carpentry and finish carpentry.

4.1.1.2. Related Sections.

- 4.1.1.2.1. Section 03300 – Concrete.

4.1.1.3. References.

- 4.1.1.3.1. MIL-V-13518C(1) Wood Preservative: Tetrachlorophenol and Pentachlorophenol, Surface Sealing Compound.
- 4.1.1.3.2. PS 20 - American Softwood Lumber Standard.
- 4.1.1.3.3. NFPA - National Design Specification for Wood Construction.

4.1.1.4. Quality Assurance.

- 4.1.1.4.1. Rough Carpentry Lumber: Visible grade stamp, of agency certified by National Forest Products Association (NFPA).
- 4.1.1.4.2. Site Made Finish Carpentry - Architectural Wood Work Institute.

4.1.1.5. Delivery, Storage, and Handling.

- 4.1.1.5.1. Do not deliver shop fabricated carpentry items until site conditions are adequate to receive the work. Protect items from weather while in transit.

**SECTION THREE**  
**TECHNICAL SPECIFICATIONS**

---

4.1.1.5.2. Store indoors, in ventilated areas with a constant, minimum temperature of sixty (60) degrees Fahrenheit, maximum relative humidity of twenty-five to fifty-five percent (25% - 55%).

4.1.2. Part 2 – Products.

4.1.2.1. Rough Carpentry Materials.

4.1.2.1.1. Lumber: PS 20; graded in accordance with established grading rules; maximum moisture content of fifteen to nineteen percent (15 – 19%); of following species and grades:

4.1.2.1.1.1. Structural Light Framing: Stress group A; select structural grade.

4.1.2.1.1.2. Non-structural Light Framing: Stress group B; construction grade.

4.1.2.1.2. Nails, Spikes and Staples: Galvanized for exterior locations, high humidity locations and treated wood; plain finish for other interior locations; size and type to suite application.

4.1.2.1.3. Bolts, Nuts, Washers, Lags, Pins and Screws: Medium carbon steel; sized to suit application; galvanized for exterior locations, high humidity locations and treated wood; plain finish for other interior locations.

4.1.2.1.3. Joist Hangers; sized and profiled to suit application; galvanized finish.

4.1.2.2. Wood Treatment.

4.1.2.2.1. Wood Preservative; in accordance with AWPB LP-22.

4.1.2.2.2. All lumber utilized for this project shall be pressure-treated wood. All posts in contact with the concrete footings or the earth shall be rated for ground contact.

4.1.2.2.3. Brush apply one coat of preservative treatment on cut ends of posts that are to be in contact with concrete footings or that are buried in the ground.

**SECTION THREE**  
**TECHNICAL SPECIFICATIONS**

---

4.1.3. Part 3 – Execution.

4.1.3.1. Framing, Furring, and Stripping.

- 4.1.3.1.1. Erect wood framing, furring, stripping and nailing members true to lines and levels. Do not deviate from true alignment more than one-quarter inch (1/4”).
- 4.1.3.1.2. Space joist members at sixteen inches (16”) on center.
- 4.1.3.1.3. Construct members of continuous pieces of longest possible lengths.
- 4.1.3.1.4. Construct and erect required built-up beams and headers.
- 4.1.3.1.5. Provide double joist headers at joist ends and around floor and ceiling openings. Bridge floor joists as detailed at midspan of members.



**SECTION FOUR  
FORM OF BID BOND**

---

**COUNTY OF BERKS**

**BID BOND FORM**

KNOW ALL MEN BY THESE PRESENTS that we, \_\_\_\_\_  
(hereinafter called the "Principal"), and \_\_\_\_\_, a  
company authorized to transact business in the Commonwealth of Pennsylvania, and having its  
principal office at \_\_\_\_\_ (hereinafter  
called the "Surety"), as Surety, are held and firmly bound unto the COUNTY OF BERKS  
(hereinafter called the "Obligee"), as Obligee, in the sum of  
\_\_\_\_\_ Dollars (\$ \_\_\_\_\_) lawful money of the  
United States of America, for payment of which we bind ourselves, and each of our respective  
heirs, legal representatives, successors and assigns, jointly and severally, by these presents, on this  
\_\_\_\_\_ day of \_\_\_\_\_, 2024.

WHEREAS, said Principal is herewith submitting to the Obligee a Bid to perform work  
for the Obligee's Wertz Covered Bridge Stair Replacement Project in Wyomissing Borough, Berks  
County, Pennsylvania, pursuant to plans, Specifications, and other Contract Documents  
incorporated into said Bid by reference; and it is a condition of the Obligee's receipt and  
consideration of said Bid that such Bid shall be accompanied by Bid Security to be held by the  
Obligee on terms embodied herein.

THEREFORE, the condition of this obligation is that if said Principal shall, in the event of  
acceptance of his Bid by Obligee and within the period specified therefore in the Bid Documents,  
enter into a written agreement with the Obligee, in accordance with the Bid as accepted, and give  
a Performance Bond and a Payment Bond to the Obligee with good and sufficient surety or  
sureties, as may be required for the faithful performance and proper fulfillment of the Contract, in  
the form specified by the Owner, and furnish required certificates of insurance, and shall enter into  
such Contract, in all respects as required by the Bid Documents, then this obligation shall be void  
and of no effect, but otherwise it shall remain in full force. In the event of the failure to enter into  
such Contract, give such bonds, and furnish such certificates within the time specified, the  
Principal and Surety shall pay to the Obligee the difference between the amount of the Principal's  
accepted Bid and any higher amount for which the Obligee may contract for the required work, as  
well as any advertising, architectural fees, legal fees (e.g., fees of attorneys, paralegals and other  
legal professionals) and other costs and expenses incurred by the Obligee by reason of the default;  
provided, however, that the obligations of the Surety hereunder shall not exceed the amount of this  
Bid Security together with interest.

**SECTION FOUR  
FORM OF BID BOND**

---

IN WITNESS WHEREOF, the Principal and Surety, intending to be legally bound, have executed this Bid Bond the day and year aforementioned.

(Individual Principal) \_\_\_\_\_ (SEAL)  
(Signature of Individual)

Witness: \_\_\_\_\_ Trading and Doing Business as: \_\_\_\_\_

(Partnership Principal) \_\_\_\_\_  
(Name of Partnership)

Witness: \_\_\_\_\_  
By: \_\_\_\_\_ (SEAL)  
By: \_\_\_\_\_ (SEAL)

(Corporation Principal) \_\_\_\_\_  
(Name of Corporation)

Attest: \_\_\_\_\_ By: \_\_\_\_\_  
(Asst.) Secretary (Vice) President

(CORPORATE SEAL)

OR (if applicable)

Attest: \_\_\_\_\_ \*By: \_\_\_\_\_  
Authorized Representative

\*Attach appropriate proof, dated as of the same date as this Bid Bond, evidencing authority to execute on behalf of the corporation.

(Corporate Surety) \_\_\_\_\_  
(Name of Surety)

---

**SECTION FOUR  
FORM OF BID BOND**

---

Witness or Attest:

\_\_\_\_\_

\*\*By: \_\_\_\_\_  
Title

(CORPORATE SEAL)

\*\*Attach an appropriate Power of Attorney, dated as of the same date as this Bid Bond, evidencing the authority of the Attorney-in-Fact to act on behalf of the Surety.

IN WITNESS WHEREOF, the Principal and Surety, intending to be legally bound, have executed this Bid Bond the day and year aforementioned.

CERTIFICATE AS TO CORPORATE PRINCIPAL

I, \_\_\_\_\_ certify that I am the \_\_\_\_\_ of the Corporation named as PRINCIPAL, in the within Bid Bond; that \_\_\_\_\_ who signed the said Bid Bond on behalf of the Principal was then \_\_\_\_\_ of said Corporation; that I know the signee's signature, and the signature thereto is genuine; and that said Bid Bond is duly signed, sealed and attested for on behalf of said Corporation by authority of its governing body.

\_\_\_\_\_  
(Secretary) (SEAL)

**SECTION FIVE  
FORM OF PERFORMANCE BOND**

---

**COUNTY OF BERKS  
PERFORMANCE BOND**

KNOW ALL MEN BY THESE PRESENTS that we, \_\_\_\_\_, as Principal (the “Principal”), and \_\_\_\_\_, a corporation organized and existing under the laws of the \_\_\_\_\_ of \_\_\_\_\_, having its principal office at \_\_\_\_\_, and authorized to do business in the Commonwealth of Pennsylvania, as Surety (the “Surety”), are held and firmly bound unto the COUNTY OF BERKS as Oblige (the “Obligee”), as hereinafter set forth in the full and just sum of \_\_\_\_\_ Dollars (\$ \_\_\_\_\_), lawful money of the United States of America, for the payment of which sum we bind ourselves, our heirs, executors, administrators, successors and assigns, jointly and severally, firmly by these presents.

**WITNESSETH THAT:**

WHEREAS, the Principal heretofore has submitted to the Oblige a certain Bid, dated \_\_\_\_\_, 2024 (the “Bid”), to deliver general construction to the Oblige, in connection with the Wertz Covered Bridge Stair Replacement Project located in Berks County, Pennsylvania pursuant to plans, Specifications and other related documents, constituting the Bid Documents, which are incorporated into the Bid by reference (the “Contract Documents”); and

WHEREAS, the Oblige is a “Contracting Body” under provisions of Act No. 385 of the General Assembly of the Commonwealth of Pennsylvania, approved by the Governor on December 20, 1967, known and cited as the “Public Works Contractors’ Bond Law of 1967” (the “Act”); and

WHEREAS, the Act, in Section 3(a), requires that, before an award shall be made to the Principal by the Oblige in accordance with the Bid, the Principal shall furnish this Performance Bond to the Oblige, with this Performance Bond to become binding upon the award of a contract to the Principal by the Oblige in accordance with the Bid; and

WHEREAS, it also is a condition of the Contract Documents that this Performance Bond shall be furnished by the Principal to the Oblige; and

**SECTION FIVE**  
**FORM OF PERFORMANCE BOND**

---

WHEREAS, under the Contract Documents, it is provided, *inter alia*, that if the Principal shall furnish this Performance Bond to the Obligee, and if the Obligee shall make an award to the Principal in accordance with the Bid, then the Principal and the Obligee shall enter into an agreement with respect to performance of such Work (the "Agreement"), the form of which Agreement is set forth in the Contract Documents.

NOW, THEREFORE, the terms and conditions of this Performance Bond are and shall be that if: (a) the Principal well, truly and faithfully shall comply with and shall perform the Work in accordance with the Contract Documents, at the time and in the manner provided in the Contract Documents, and if the Principal shall satisfy all claims and demands incurred in or related to the performance of the Contract Documents by the Principal or growing out of the performance of the Contract Documents by the Principal, and if the Principal shall indemnify completely, defend and save harmless the Obligee and all of its officers, agents and employees from any and all costs and damages, including, but not limited to, liquidated damages which the Obligee and all of its officers, agents and employees may sustain or suffer by reason of the failure of the Principal to do so, and if the Principal shall reimburse completely and shall pay to the Obligee any and all costs and expenses which the Obligee and all of its officers, agents and employees may incur by reason of any such default or failure of the Principal, including, but not limited to, legal fees (e.g., fees of attorneys, paralegals and other legal professionals) and professional fees resulting from such default or failure of the Principal, consequential, incidental and delay damages resulting from such default or failure of the Principal, liquidated damages in accordance with the Contract Documents and actual damages caused by delayed performance or non-performance of the Contract Documents if liquidated damages are not provided for in the Contract Documents, and (b) if the Principal shall remedy, without cost to the Obligee, all defects which may develop during the period of one (1) year from the date of final completion by the Principal and acceptance of the Obligee of the Work to be performed under the Contract Documents, which defects, in the sole judgment of the Obligee or its legal successors in interest, shall be caused by or shall result from defective or inferior materials or workmanship, then this Performance Bond shall be void; otherwise, this Performance Bond shall be and shall remain in force and effect and all claims, demands, costs, expenses and damages including, but not limited to, legal fees and professional fees resulting from the default or failure of Principal, consequential, incidental and delay damages resulting from such default or failure of the Principal, liquidated damages in accordance with the Contract Documents and actual damages caused by delayed performance or non-performance of the Contract Documents if liquidated damages are not provided for in the Contract Documents, shall be payable by Principal and Surety upon demand of Obligee; provided, however, that the obligations of the Surety hereunder shall not exceed the amount of this Performance Bond, as this Performance Bond is amended, whether automatically or in writing, in accordance with the terms hereof.

This Performance Bond is executed and delivered under and subject to the Act, to which reference hereby is made.

The Principal and the Surety agree that any alterations, changes and/or additions to the Contract Documents, and/or any alterations, changes and/or additions to the Work to be performed under the Contract Documents, and/or any giving by the Obligee of any extensions of time for the

---

**SECTION FIVE**  
**FORM OF PERFORMANCE BOND**

---

performance of the Work in accordance with the Contract Documents, and/or any act of forbearance of either the Principal or the Obligee toward the other with respect to the Contract Documents, and/or the reduction of any percentage to be retained by the Obligee as permitted by the Contract Documents, shall not release and/or discharge, in any manner whatsoever, the Principal and the Surety, or either of them, or their heirs, executors, administrators, successors and assigns, from liability and obligations under this Performance Bond; and the Surety, for value received, does waive notice of any such alterations, changes, additions, extensions of time, acts of forbearance and/or reduction of retained percentage.

Provided, that it is expressly agreed that this Performance Bond shall be deemed amended automatically and immediately, without formal and separate amendments hereto, upon any amendment to the Contract Documents not increasing the contract sum in the aggregate by more than twenty percent (20%), so as to bind the Principal and the Surety to the full and faithful performance of the Contract Documents as so amended and the Surety, for value received, does waive notice of any such amendment to the Contract Documents not increasing the contract sum in the aggregate by more than twenty percent (20%). The term "Amendment", wherever used in this Performance Bond and whether referring to this Performance Bond or the Contract Documents shall include, without limitation, any alteration, addition, extension or modification of any character whatsoever.

Provided, further, that no final settlement between the Obligee and the Principal shall abridge the right of any beneficiary hereunder, whose claim may be unsatisfied.

In the event that the Obligee incurs legal fees for actual or potential default or enforcement of its rights under the Contract Documents or Performance Bond, the Surety agrees to pay for all legal fees and costs incurred by the Obligee.

Any dispute resolution proceeding, legal or equitable, under this Performance Bond, shall be instituted in the Court of Common Pleas of Berks County and not elsewhere. In such dispute resolution proceeding, Obligee may join both Principal and Surety as parties, and Principal and Surety hereby consent to such joinder, jurisdiction and venue. This Performance Bond shall be governed by, construed and enforced in accordance with the laws of the Commonwealth of Pennsylvania, without regard to principles of conflicts of law.

IN WITNESS WHEREOF, the Principal and the Surety cause this Performance Bond to be signed, sealed and delivered this \_\_\_\_ day of \_\_\_\_\_, 2024.

(Individual Principal)

WITNESS:

\_\_\_\_\_  
(Signature of Individual) (SEAL)

Trading and Doing Business as

\_\_\_\_\_  
\_\_\_\_\_

---

---

**SECTION FIVE  
FORM OF PERFORMANCE BOND**

---

\*\*\*\*\*

(Partnership Principal)

WITNESS:

\_\_\_\_\_  
(Name of Partnership)

\_\_\_\_\_

By: \_\_\_\_\_ (SEAL)  
Partner

\_\_\_\_\_

By: \_\_\_\_\_ (SEAL)  
Partner

\_\_\_\_\_

By: \_\_\_\_\_ (SEAL)  
Partner

\*\*\*\*\*

(Corporate Principal)

ATTEST:

\_\_\_\_\_  
(Name of Corporation)

\_\_\_\_\_  
Secretary (Assistant Secretary)

By: \_\_\_\_\_ (SEAL)  
President (Vice President)

(CORPORATE SEAL)

or (if appropriate)

WITNESS:

\_\_\_\_\_  
(Name of Corporation)

\_\_\_\_\_

\*By: \_\_\_\_\_  
(Authorized Representative)

\*Attach appropriate proof, with raised corporate seal, dated as of the same date as the Performance Bond, evidencing authority to execute on behalf of the corporation.

**SECTION FIVE  
FORM OF PERFORMANCE BOND**

---

\*\*\*\*\*  
(Corporate Surety)

WITNESS:

\_\_\_\_\_  
(Name of Corporation)

\*\*By: \_\_\_\_\_

(Attorney-in-Fact)

\_\_\_\_\_  
\*\*Attach an appropriate power of attorney, with raised corporate seal, dated as of the same date as the Performance Bond, evidencing the authority of the Attorney-in-Fact to act on behalf of the Surety.



**SECTION SIX  
FORM OF PAYMENT BOND**

---

**COUNTY OF BERKS  
PAYMENT BOND**

KNOW ALL MEN BY THESE PRESENTS that we, \_\_\_\_\_,  
as Principal (the “Principal”), and \_\_\_\_\_, a company organized and  
existing under the laws of the \_\_\_\_\_ of \_\_\_\_\_, with a principal  
office at \_\_\_\_\_  
\_\_\_\_\_, and authorized to do business in the Commonwealth of  
Pennsylvania, as Surety (the “Surety”), are held and firmly bound, unto the COUNTY OF BERKS  
as Obligee (the “Obligee”), as hereinafter set forth, in the full and just sum of  
\_\_\_\_\_ Dollars (\$\_\_\_\_\_) lawful money of the United  
States of America, for the payment of which sum we bind ourselves, our heirs, executors,  
administrators, successors and assigns, jointly and severally, firmly by these presents.

**WITNESSETH THAT:**

WHEREAS, the Principal heretofore has submitted to the Obligee a certain Bid, dated  
\_\_\_\_\_, 2024 (the “Bid”), to perform general construction Work for the Obligee, in  
connection with the Wertz Covered Bridge Stair Replacement Project located in Wyomissing  
Borough, Berks County, Pennsylvania, pursuant to Drawings, Specifications and other related  
documents, constituting the Bidding Documents, which are incorporated into the Bid by reference  
(the “Contract Documents”); and

WHEREAS, the Obligee, is a “Contracting Body” under provisions of Act No. 385 of the  
General Assembly of the Commonwealth of Pennsylvania, approved by the Governor on  
December 20, 1967, known as and cited as the “Public Works Contractors’ Bond Law of 1967” (the  
“Act”); and

WHEREAS, the Act, in Section 3(a), requires that, before an award shall be made to the  
Principal by the Obligee in accordance with the Bid, the Principal shall furnish this Payment Bond to  
the Obligee, with this Payment Bond to become binding upon the award of a contract to the Principal  
by the Obligee in accordance with the Bid; and

**SECTION SIX**  
**FORM OF PAYMENT BOND**

---

WHEREAS, it also is a condition of the Contract Documents that this Payment Bond shall be furnished by the Principal to the Obligee; and

WHEREAS, under the Contract Documents, it is provided, *inter alia*, that if the Principal shall furnish this Payment Bond to the Obligee, and if the Obligee shall make an award to the Principal in accordance with the Bid, then the Principal and the Obligee shall enter into an agreement with respect to performance of such Work (the "Contract"), the form of which Agreement is set forth in the Contract Documents.

NOW, THEREFORE, the terms and conditions of this Payment Bond are and shall be that if the Principal, and if all assignees of the Principal, promptly shall pay or shall cause to be paid, in full, all money which may be due any claimant supplying labor or materials in the prosecution and performance of the Work in accordance with the Contract Documents, including, without limitation, any amendment, extension or addition to the Contract Documents, for material furnished, labor supplied or labor performed, then this Payment Bond shall be void; otherwise, this Payment Bond shall be and shall remain in force and effect.

This Payment Bond, as provided by the Act, shall be solely for the protection of claimants supplying labor or materials to the Principal, any assignees of the Principal, in the prosecution of the Work covered by the Contract Documents, including, without limitation, any amendment, extension or addition to the Contract Documents and is conditioned for the prompt payment of all such materials furnished and labor supplied or performed in the prosecution of any portion of the Work. The term "claimant", when used herein and as required by the Act, shall mean any individual, firm, partnership, association or corporation. The phrase "labor or materials" when used herein and as required by the Act, shall include, without limitation, public utility services and reasonable rentals of equipment, but only for periods when the equipment rented is actually used at the site of the Work covered by the Contract Documents. As required by the Act, the provisions of this Payment Bond shall be applicable whether or not the material furnished or labor performed enters into and becomes a component part of the public building, public Work or public improvement contemplated by the Contract Documents.

As provided and required by the Act, the Principal and the Surety agree that any claimant, who has performed labor or furnished material in the prosecution of the Work in accordance with the Contract Documents, including, without limitation, any amendment, extension or addition to the Contract Documents, and who has not been paid therefore, in full, before the expiration of ninety (90) days after the day on which such claimant performed the last of such labor or furnished the last of such materials for which payment is claimed, may institute an action upon this Payment Bond, in the name of the claimant, in assumpsit, to recover any amount due the claimant for such labor or material; and may prosecute such action to final judgment and may have execution upon the judgment; provided, however, that: (a) any claimant who has a direct contractual relationship with any subcontractor of the Principal or any assignees of any subcontractor of the Principal, but has no contractual relationship, express or implied, with the Principal, may institute an action upon this Payment Bond only if such claimant first shall have given written notice, served in the manner provided in the Act, to the Principal, within ninety (90) days from the date upon which such claimant performed the last of the labor or

---

**SECTION SIX**  
**FORM OF PAYMENT BOND**

---

furnished the last of the materials for which payment is claimed, stating, with substantial accuracy, the amount claimed and the name of the person for whom the Work was performed or to whom the material was furnished; and (b) no action upon this Payment Bond shall be commenced after the expiration of one (1) year from the day upon which the last of the labor was performed or material was supplied, for the payment of which such action is instituted by the claimant.

This Payment Bond is executed and delivered under and subject to the Act, to which reference hereby is made.

The Principal and the Surety agree that any alterations, changes and/or additions to the Contract Documents, and/or any alterations, changes and/or additions to the Work to be performed under the Contract Documents, and/or any giving by the Obligee of any extensions of time for the performance of the Work in accordance with the Contract Documents, and/or any act of forbearance of either the Principal or the Obligee toward the other with respect to the Contract Documents, and/or the reduction of any percentage to be retained by the Obligee as permitted by the Contract Documents, and/or alterations and/or changes which materially increase the liability and/or obligations of the Principal and the Surety under this Payment Bond, shall not release, and/or discharge, in any manner whatsoever, the Principal and the Surety, or either of them, or their heirs, executors, administrators, successors and assigns, from liability and obligations under this Payment Bond; and the Surety, for value received, does waive notice of any such alterations, changes, additions, extensions of time, acts of forbearance and/or reduction of retained percentage and/or other material increase in the liability and obligations of the Principal and the Surety under this Payment Bond.

Provided, that it is expressly agreed that this Payment Bond shall be deemed amended automatically and immediately, without formal and separate amendments hereto, upon any amendment to the Contract Documents not increasing the contract price in the aggregate by more than twenty percent (20%), so as to bind the Principal and the Surety to the full and faithful performance of the Contract Documents as so amended and the Surety, for value received, does waive notice of any such amendment to the Contract Documents not increasing the contract price in the aggregate by more than twenty percent (20%). The term "Amendment", wherever used in this Payment Bond and whether referring to this Payment Bond or the Contract Documents, shall include any alteration, addition, extension or modification, whether material or not, and of any character whatsoever.

Provided, further, that no final settlement between the Obligee and the Principal shall abridge the right of any beneficiary hereunder, whose claim may be unsatisfied.

In the event that the Obligee incurs legal fees (e.g., fees of attorneys, paralegals and other legal professionals) for actual or potential default or enforcement of its rights under the Contract Documents or Payment Bond, the Surety agrees to pay for all legal fees and costs incurred by the Obligee.

Any dispute resolution proceeding, legal or equitable, under this Payment Bond, shall be instituted in the Court of Common Pleas of Berks County and not elsewhere. In such dispute

---

**SECTION SIX  
FORM OF PAYMENT BOND**

---

resolution proceeding, Obligee may join both Principal and Surety as parties, and Principal and Surety hereby consent to such joinder, jurisdiction and venue. This Payment Bond shall be governed by, construed and enforced in accordance with the laws of the Commonwealth of Pennsylvania, without regard to principles of conflicts of law.

IN WITNESS WHEREOF, the Principal and the Surety cause this Payment Bond to be signed, sealed and delivered this \_\_\_\_\_ day of \_\_\_\_\_, 2024.

(Individual Principal)

\_\_\_\_\_  
(Signature of Individual) (SEAL)

WITNESS:

Trading and Doing Business as

\_\_\_\_\_

\_\_\_\_\_

\*\*\*\*\*

(Partnership Principal)

WITNESS:

\_\_\_\_\_  
(Name of Partnership)

\_\_\_\_\_

BY: \_\_\_\_\_ (SEAL)  
Partner

\_\_\_\_\_

BY: \_\_\_\_\_ (SEAL)  
Partner

\_\_\_\_\_

BY: \_\_\_\_\_ (SEAL)  
Partner

\*\*\*\*\*

(Corporate Principal)

ATTEST:

\_\_\_\_\_  
(Name of Corporation)

\_\_\_\_\_  
Secretary (Assistant Secretary)

BY: \_\_\_\_\_  
President (Vice President)

(CORPORATE SEAL)

---

**SECTION SIX  
FORM OF PAYMENT BOND**

---

or (if appropriate)

WITNESS:

\_\_\_\_\_  
(Name of Corporation)

\*BY: \_\_\_\_\_  
(Authorized Representative)

\_\_\_\_\_  
\* Attach appropriate proof, with raised corporate seal, dated as of the same date as the Payment Bond, evidencing authority to execute on behalf of the corporation.

\* \* \* \* \*  
(Corporate Surety)

WITNESS:

\_\_\_\_\_  
(Name of Corporation)

\*\*BY: \_\_\_\_\_  
(Attorney-in-Fact)

\_\_\_\_\_  
\*\* Attach an appropriate power of attorney, with raised corporate seal, dated as of the same date as the Payment Bond, evidencing the authority of the Attorney-in-Fact to act on behalf of the Surety.

**SECTION SEVEN  
CONTRACT**

---

**CONTRACT #PC-XXXXXX-XX**

THIS CONTRACT (“Contract”) is entered into by and between the **County of Berks** with offices at Berks County Services Center, 633 Court Street, Reading, Pennsylvania, 19601 (hereinafter “Owner”) and **Contractor** with offices at [     ] (hereinafter “Contractor”).

**Background**

The Owner desires to engage the Contractor for the delivery of general construction of the Wertz Covered Bridge Stair Replacement Project in accordance with the requirements set forth in the Owner’s Invitation to Bid #24-08-GR, inclusive of all Amendments (hereinafter “ITB”), and Contractor’s Bid thereto dated Month Day, Year (hereinafter “Bid”), both of which are hereby incorporated into this Contract by reference.

NOW, THEREFORE, in consideration of the mutual promises and covenants contained herein, and intending to be legally bound hereby, the parties agree as follows:

**1.     Contract Documents**

In addition to the ITB and Bid, the Contract Documents consist of this Contract, Conditions of the Contract (General, Supplementary and other conditions), Drawings, Specifications, Addenda issued prior to execution of this Contract, other documents listed in this Contract, and modifications issued after execution of this Contract and such documents are as fully a part of the Contract as if attached to this Contract or repeated herein (all of which together are hereinafter referred to as the “Contract”). The Contract represents the entire and integrated contract between the parties hereto and supersedes prior negotiations, representations or agreements, either oral or written. An enumeration of the Contract Documents, other than modifications, appears in Article 31, below.

**2.     The Work of this Contract**

- 2.1     Subject to the terms and conditions set forth in this Contract, the Owner hereby engages the Contractor to provide construction services set forth in the ITB on behalf of the Owner consistent with the terms of the Contract.
  
- 2.2     The Contractor shall fully execute the work described in the Contract, except to the extent specifically indicated in the Contract Documents to be the responsibility of others.
  
- 2.3     Owner may, from time to time, without invalidating the Contract, order additional work or alterations to the Contract Documents, by amending, modifying, changing, adding to, deducting from, or altering the work described in the Contract Documents. The provisions of the Contract shall apply to all such additional work and alterations with the same effect as if they were embodied in the original Contract Documents. No order for additional work or alterations given to Contractor and no cancellation of any such

## SECTION SEVEN CONTRACT

---

order shall be deemed authorized, nor shall it bind or obligate Owner in any way unless such order for additional work or alterations shall have been written and previously signed on behalf of Owner by an authorized representative of Owner. Where work commenced by Contractor prior to the time a claim is made by Contractor that such work is not provided for in the Contract Documents, and where Owner shall not have issued a written, signed order for additional work in accordance with the Contract Documents, such work shall be deemed to have been included in the original Contract Documents and shall not be considered an order to perform additional work or alteration under the Contract.

- 2.3.1 Prior to performing any additional work, Contractor shall furnish detailed written estimates of the cost of additional work involved to the Owner in a manner that is satisfactory to the Owner.
- 2.3.2 Any order by the Owner to the Contractor for additional work or alterations given pursuant to the Contract Documents may recite that the Contract Sum will be adjusted either up or down, in which event the Contract Sum (as defined in Paragraph 4.2, below) shall be adjusted at the option of the Owner, in its discretion, on any of the following bases that may be designated by the Owner:
  - 2.3.2.1 By estimate, negotiation or acceptance of a lump sum;
  - 2.3.2.2 The unit prices set forth in Paragraph 4.4 of this Contract or if no such unit prices exist, then the best applicable unit prices that may be agreed upon by both the Contractor and the Owner;
  - 2.3.2.3 By cost and a percentage fee, or by cost and a fixed fee, in each case subject to a guaranteed maximum price;
  - 2.3.2.4 On the basis of the reasonable value of the additional work or alterations required of the Contractor;
  - 2.3.2.5 In the case of an omission of any work by the Contractor, the Contract Sum shall be reduced in an amount equal to the estimated, but reasonable value of the work omitted by the Contractor in relation to the Contract Sum; or
  - 2.3.2.6 Any combination of the above bases.
- 2.3.3 If any order given by the Owner to the Contractor for additional work or alterations given pursuant to the Contract Documents does not specify the amount or rate by which the Contract Sum, shall be adjusted, then there shall be no adjustment in the Contract Sum unless within a reasonable time not exceeding Seven (7) calendar days after delivery of such order and, in any event before the

## SECTION SEVEN CONTRACT

---

commencement of the particular work in question, Contractor shall submit a written claim to Owner for an adjustment, or further adjustment in the Contract Sum. If an order given by the Owner to the Contractor for additional work or alterations does not recite that the time for the completion of the work will be extended or shortened, then there shall be no such extension or shortening. If Owner so chooses, such order may recite that said time will be extended or shortened by a stated amount, in which case there shall be no further extension or shortening of said time, unless Contractor within the time for submitting a written claim for adjustment in the Contract Sum under this Paragraph 2.2.3 shall submit a written claim to Owner for a different extension or shortening of said time. Upon delivery of any such claim by Contractor to Owner, Owner shall have the right to cancel the additional order for changes giving rise to such claim by Contractor, but if Owner does not cancel same, then Owner and Contractor shall endeavor to agree on the amount by which the Contract Sum should be adjusted, or on the date when all of said work shall be completed. If agreement on any of said points is reached, it shall be reduced to writing and signed by authorized representatives of both Contractor and Owner. Should Owner and Contractor fail to reach an agreement on all of said points within a reasonable time, Owner may, nevertheless, direct Contractor to proceed with the Work as ordered.

### **3. Start of Work and Substantial Completion**

- 3.1 The Contract shall commence upon the issuance of a formal Notice to Proceed (NTP) letter authored by the Owner's representative to order required material and perform other preconstruction activities and must be completed no later than sixty (60) calendar days following issuance of the NTP to commence performance of contract work ("Contract Period"). The Contractor acknowledges that the time period for completion of the work described in the Contract Documents is suitable to enable the Contractor to complete such work in full compliance with all applicable codes, laws, ordinances and regulations affecting the project. Notwithstanding the foregoing, the Owner reserves the right, in the Owner's sole and absolute discretion, upon notice to the Contractor, to extend the Contract or any part of the Contract for up to Three (3) months upon the same terms and conditions except that the contract price for the additional time period shall be a prorated amount of the Contract Sum set forth in Section 4.2 of this Contract. This will be utilized to prevent a lapse in Contract coverage and only for the time necessary, up to Three (3) months, to enter into a new contract

### **4. Contract Sum**

- 4.1 The Owner shall pay the Contractor the Contract Sum in current funds for the Contractor's performance of the Contract.



**SECTION SEVEN  
CONTRACT**

---

4.2 The Owner shall pay the Contractor \_\_\_\_\_ (“Contract Sum”) in current funds, subject to additions and deductions as provided in the Contract Documents, for the Contractor’s proper performance of the work in accordance with the Contract Documents during the Contract Period as detailed below:

Item No.	Quantity	Item Description	Unit Price	Total Price
1	1	Mobilization/demobilization		
2	1	Bonds and Insurance		
3	1	Demolition		
4	1	Excavation & Grading		
5	1	Concrete Footings		
6	1	Wood framing, decking and guards		
7	1	Aluminum handrails		

4.3 The Contract Sum is based upon the following alternates, if any, which are described in the Contract Documents and are hereby accepted by Owner: Not Applicable.

4.4 Unit prices, if any, are as follows: Not Applicable.

4.5 The Contractor shall deliver N/A within five (5) days of the Owner’s request for delivery. Transportation terms are F.O.B. DESTINATION for all deliveries. The Contract Sum includes, without limitation, all transportation, delivery, placement, handling charges, overhead, labor and profit, etc. Furthermore, the Contractor should confirm with the Owner the delivery requirements before making delivery. In emergency situations, the Contractor shall deliver appropriate labor, material, and equipment within Forty-Eight (48) hours after the Owner’s request for delivery

**5. Notices**

5.1 All necessary coordination and communication required to carry out this Contract, including meetings between the parties, as well as all written notices, shall be done through the individuals indicated below. Written notices shall be effective when delivered by hand, or if sent by registered or certified mail, or verified facsimile, or by confirmed courier to the address of each party indicated below:

**SECTION SEVEN  
CONTRACT**

---

	<i>Owner:</i>	<i>Contractor:</i>
Attention	Brendan Lederer, Assist Director, Parks and Recreation Department	
Address	2083 Tulpehocken Road Wyomissing, PA 19610	
Telephone	610-372-8939	
Email	blederer@berkspa.gov.com	

5.2. Neither the Owner's nor the Contractor's representative shall be changed without Ten (10) days written notice to the other party. Any proposed replacement for the Contractor's representative must be approved by the Owner in writing.

**6. Payments**

Based upon invoices submitted to the Owner by the Contractor, the Owner shall make payments on account of the Contract Sum to the Contractor as provided in Section 34 of the Instructions to Bidders and General Conditions of Contract.

**7. Insurance**

Prior to commencement of performance of this Contract, Contractor shall furnish to the Owner a certificate of insurance evidencing all required coverage as provided in Section 16 of the Instructions to Bidders and General Conditions of Contract.

**8. Availability of Appropriated Funds**

The parties agree that any and all payments due from the Owner, as required under the terms of the Contract, are contingent upon the availability of appropriated funds.

**9. Taxes**

The Owner is exempt from all Federal Excise Taxes and Pennsylvania Sales Taxes, as a political subdivision of the Commonwealth of Pennsylvania. The Owner's registration number with the Internal Revenue Service is 23-6003049. Net prices shown in the Bid as incorporated in this Contract shall exclude such Federal and State taxes. This statement is not meant to exempt the Contractor from the payment of sales or use tax required to be paid with respect to its purchase or use of tangible personal property used or transferred in connection with the performance herein.

**10. Records, Audit and Inspection**

10.1 Contractor shall maintain such records as may be necessary to adequately reflect the accuracy of Contractor's charges and invoices for reimbursement under this Contract and such other additional records as the Owner may reasonably require in connection with this Contract. Contractor shall preserve such records in accordance with statutory requirements, but in no case for less than three (3) years after the date of

## SECTION SEVEN CONTRACT

---

final payment, without additional reimbursement or compensation therefor. The Owner and its duly authorized representatives shall have the right, from time to time, and upon reasonable notice, to audit, inspect and verify the records kept by Contractor in connection with this Contract. The Owner and its duly authorized representatives shall have the right to visit, observe, audit, and inspect, during the Contractor's normal business hours, Contractor's production and related facilities utilized to perform its obligations under this Contract.

### 10.2 Monitoring.

Contractor shall make available to Owner during the term of this Contract all pertinent financial, program, administrative and personnel records, reports, documents, and files related directly or indirectly to Contractor's activities under and in compliance with this Contract.

### 11. **Indemnity**

Contractor agrees to defend (with counsel reasonably acceptable to Owner), indemnify and hold harmless the Owner, its elected officials, employees and agents from and against any and all liability, damages, claims, suits, liens, and judgments (including reasonable attorney's fees), of whatever nature, for injuries to or death of any person or persons, or loss of or damage to property, to the extent attributable to the negligent acts or omissions or willful misconduct of Contractor or its subcontractors or any of their respective agents, servants, or employees or Contractor's failure to perform in accordance with the provisions of this Contract.

### 12. **Force Majeure**

Neither party shall be liable for any failure or delay in its performance resulting from any cause beyond its reasonable control including, but not limited to, acts of God; acts or omissions of civil or military authority; fires, floods; unusually severe weather; strikes or other labor disputes; embargoes; wars; political strife; riots; delays in transportation; sabotage; or fuel, power, material or labor shortages, provided that the affected party notifies the other party, in writing, within forty-eight (48) hours subsequent to the commencement of an occurrence of force majeure.

### 13. **Claims for Consequential and/or Incidental Damages**

The Contractor waives claims against the Owner for lost or expected profits, consequential damages and/or incidental damages arising out of or relating to this Contract.

### 14. **Publicity**

Neither Contractor nor any tier subcontractor shall use the name of the Owner or quote the opinion of any Owner employee in any advertising, publicity, endorsement or testimonial, without the prior written approval of the Owner.

## SECTION SEVEN CONTRACT

---

### **15. Compliance with Laws**

In the performance of this Contract, Contractor shall comply with all applicable laws, ordinances, rules and regulations of governmental authorities. Contractor shall minimize pollution and shall strictly comply with all applicable environmental laws and regulations. Contractor shall give required notices, and secure and pay for any permits, licenses, and easements required for supply of Goods and Services. The Contractor shall give any and all necessary formal notices required in conjunction with the lawful supply of the Goods and Services.

### **16. Health and Safety**

The Contractor shall, at all times, control the health, safety and welfare of its employees and subcontractors. Contractor shall:

- 16.1 comply with all federal, state and local regulations, as well as all safety information and instructions as may be set forth in writing or otherwise provided by the Owner;
- 16.2 promptly report to the Owner all incidents with potentially adverse safety, health or environmental implications, including slips, falls, equipment malfunctions, fume releases and any situation requiring first-aid or medical observations or treatment;
- 16.3 promptly report to the Owner all cases Contractor determines to be recordable on the OSHA 300 log or its equivalent and upon request, provide the Owner with a copy of the OSHA 300 log and all supporting forms;
- 16.4 properly maintain, inspect and supervise its designated work area and roadways to keep them in reasonably safe condition. This responsibility includes Contractor's right and duty to conduct reasonable and necessary maintenance in the work area and of the roadways to prevent unsafe work conditions from existing. Contractor shall regularly conduct safety audits and inspections to ensure compliance with its responsibility to maintain a reasonably safe work area;
- 16.5 supply the applicable safety data sheets on all Goods and Services supplied to the Owner or used on Owner property;
- 16.6 use, handle, store and dispose of any hazardous materials or waste while on the Owner's property in strict compliance with applicable laws and as instructed in the safety data sheet(s); and
- 16.7 keep the Owner's property free of waste as the work progresses and, on completion of such activities, leave the site "broom clean" and tools, equipment and materials furnished shall be so placed and maintained as to permit unobstructed access to the work and to minimize exposure to personal injury or fire loss in a location approved by the Owner. The Owner may remove waste or store Contractor's tools, equipment and

**SECTION SEVEN  
CONTRACT**

---

materials if Contractor fails to properly do so and the Contractor shall reimburse the Owner for any costs incurred, including charges for employee time, within seven (7) days of demand.

**17. Equal Employment Opportunity**

During the performance of the Contract, the Contractor shall not discriminate against any employees or applicant for employment because of race, color, religion, sex, or national origin. The Contractor will take affirmative action to ensure that applicants are employed, and that employees are treated during employment, without regard to race, color, religion, sex or national origin. Such action shall include, but not be limited to, the following: employment, upgrading, demotion, or transfer, recruitment or recruitment advertising; layoff or termination; rates of pay or other forms of compensation; and selection for training, including apprenticeship. The Contractor agrees to post in conspicuous places, available to employees and applicants for employment, notices setting forth the provisions of this paragraph.

**18. Independent Contractor**

The employees, subcontractors, methods, facilities, and equipment used by Contractor shall be at all times under Contractor's direction and control. Contractor's relationship to the Owner under this Contract shall be that of an independent contractor, and nothing in this Contract shall be construed to constitute Contractor, its subcontractors or any of their employees as an employee, agent, associate, joint venturer, or partner of the Owner.

**19. Termination**

The Contract may be terminated by the Owner as provided in Section 44 of the Instructions to Bidders and General Conditions of Contract.

**20. Employees of Contractor**

20.1 Contractor agrees that each of its employees will be properly qualified and will use reasonable care in the performance of services while on Owner's property. If the Owner, in the Owner's sole opinion, determines, for any reason, that the qualifications, actions or conduct of any particular Contractor employee is inconsistent with Contractor's obligations under this Contract by performing unsatisfactory services, interfering with the operation of the Owner's facilities, bothering or annoying any occupants, visitors, or other vendors then at facility, or that such actions or conduct is otherwise detrimental to the Owner, then upon the Owner's written notice, Contractor shall immediately provide a qualified replacement.

20.2 Contractor shall advise its employees and the employees of its subcontractors and agents that:

20.2.1 It is the policy of the Owner to provide a drug-free work environment. To that end the Owner prohibits the consumption of alcohol or illegal use, possession,

**SECTION SEVEN  
CONTRACT**

---

sale, manufacture, dispensing, and distribution of drugs or other controlled substances while supplying Goods and Services or on Owner's property on the work site, and prohibits in the workplace the presence of an individual with such substances in the body for non-medical reasons.

- 20.2.2 Any employee of Contractor who is found in violation of the policy may be removed or barred from the work site at the discretion of the Owner.

**21. Governing Law and Jurisdiction**

This Contract shall be interpreted under the substantive law of the Commonwealth of Pennsylvania, without giving effect to its principles of conflicts of law. EACH PARTY IRREVOCABLY CONSENTS TO THE EXCLUSIVE JURISDICTION AND VENUE OF THE COURT OF COMMON PLEAS OF BERKS COUNTY, COMMONWEALTH OF PENNSYLVANIA, AND IRREVOCABLY AGREES THAT ALL ACTIONS OR PROCEEDINGS BETWEEN THE PARTIES, INCLUDING, BUT NOT LIMITED TO, THOSE ACTIONS OR PROCEEDINGS RELATING TO THIS CONTRACT, SHALL BE LITIGATED IN SUCH COURT.

**22. Subcontractors**

- 22.1 The Contractor shall not subcontract with or employ any entity or individual who is currently suspended or debarred by the Commonwealth of Pennsylvania or federal government during the term of this Contract or any extensions or renewals thereof. The Owner shall have the right to require the Contractor to terminate such subcontracts or employment at no cost to the Owner. The Contractor agrees to reimburse the Owner for costs and expenses incurred due to the Contractor's noncompliance with the terms of this certification requirement.

**23. Severability**

The provisions of this Contract shall be deemed to be severable. Consequently, in the event that any provision of this Contract is found to be void or unenforceable, such findings shall not be construed to render any other provision of this Contract either void or unenforceable, and all other provisions shall remain in full force and effect unless the provisions which are void or unenforceable shall substantially affect the rights or obligations granted to or undertaken by either party.

**24. Assignment**

All terms, provisions, covenants and contracts contained in the Contract Documents shall extend to and be obligatory on the successors and assigns of the Contractor and Owner, but Contractor shall not assign the Contract, or any part thereof, or any of the payments to become due under the Contract, or any portion thereof, nor delegate any duties except with the written consent of the Owner.

**SECTION SEVEN  
CONTRACT**

---

**25. Reservation of Rights**

Either party's waiver of any of its remedies afforded hereunder or by law is without prejudice and shall not operate to waive any other remedies which such party shall have available to it, nor shall such waiver operate to waive such party's rights to any remedies for future breach, whether of a like or different character. Furthermore, any termination or assignment of this Contract shall not relieve or release either party hereto from any rights, liabilities, or obligations which it has accrued under law or under the terms of this Contract prior to the date of such termination or assignment.

**26. Integrity Provisions**

- 26.1 It is essential that those who seek to contract with the Owner observe high standards of honesty and integrity. They must conduct themselves in a manner that fosters public confidence in the integrity of the Owner's procurement process.
- 26.2 In furtherance of this policy, Contractor agrees to the following:
- 26.2.1 Contractor shall maintain the highest standards of honesty and integrity during the performance of this Contract and shall take no action in violation of state or federal laws or regulations or any other applicable laws or regulations or other requirements applicable to Contractor or that governs contracting with the Owner and Commonwealth.
- 26.2.2 Contractor shall establish and implement a written business integrity policy, which includes, at a minimum, the requirements of these provisions as they relate to Contractor employee activity with the Owner and Commonwealth; Owner and Commonwealth employees, and which is distributed and made known to all Contractor employees.
- 26.2.3 Contractor, its affiliates, agents and employees shall not influence, or attempt to influence any Owner or Commonwealth employee to breach the standards of ethical conduct for Owner or Commonwealth employees set forth in the *Public Official and Employees Ethics Act, 65 Pa.C.S. §§1101 et seq.*; the *State Adverse Interest Act, 71 P.S. §776.1 et seq.*; and the *Governor's Code of Conduct, Executive Order 1980-18, 4 Pa. Code §7.151 et seq.*, or to breach any other state or federal law or regulation.
- 26.2.4 Contractor, its affiliates, agents and employees shall not offer, give or agree or promise to give any gratuity to a Owner and/or Commonwealth official or employee or to any other person at the direction or request of any Owner and/or Commonwealth official or employee.
- 26.2.5 Contractor, its affiliates, agents and employees shall not offer, give or agree or promise to give any gratuity to an Owner official or employee or to any other
-

## SECTION SEVEN CONTRACT

---

person, the acceptance of which would violate the *Governor's Code of Conduct, Executive Order 1980-18, 4 Pa. Code §7.151 et seq.* or any statute, regulation, statement of policy, management directive or any other published standard of the Owner and Commonwealth.

- 26.2.6 Contractor, its affiliates, agents and employees shall not, directly or indirectly, offer, confer, or agree to confer any pecuniary benefit on anyone as consideration for the decision, opinion, recommendation, vote, other exercise of discretion, or violation of a known legal duty by any Owner or Commonwealth official or employee.
- 26.2.7 Contractor, its affiliates, agents, employees or anyone in privity with him or her shall not accept or agree to accept from any person, any gratuity in connection with the performance of work under the contract, except as provided in the Contract.
- 26.2.8 Contractor shall not have a financial interest in any other provider, subcontractor or supplier providing services, labor or material on this program, unless the financial interest is disclosed to the Owner in writing and the Owner consents to Contractor's financial interest prior to Owner execution of the Contract. Contractor shall disclose the financial interest to the Owner at the time of bid or proposal submission, or if no bids or proposals are solicited, no later than Contractor's submission of the contract signed by Contractor.
- 26.2.9 Contractor must promptly refer to the Department of Justice Office of the Inspector General (OIG) any credible evidence that a principal, employee, agent, subrecipient, contractor subcontractor or other person has, in connection with funds under this award (1) submitted a claim that violates the False Claims Act or (2) committed a criminal or civil violation of laws pertaining to fraud, conflict of interest, bribery, gratuity or similar misconduct. Potential fraud, waste, abuse or misconduct involving or relating to funds under this contract should be reported to the OIG by (1) mail directed to: Office of the Inspector General, U.S. Department of Justice, Investigations Division 950 Pennsylvania Avenue, N.W. Room 4706, Washington, DC 20530; (2) email to [oig.hotline@usdoj.gov](mailto:oig.hotline@usdoj.gov) and/or (3) the DOJ OIG hotline: at (800) 869-4499 (phone) or (202) 616-9881. Additional information is available from the DOJ OIG website at <http://www.usdoj.gov/oig>.
- 26.2.10 Restrictions and certifications regarding non-disclosure agreements and related matters.
- 26.2.10.1 Contractor shall not require any employee or contractor to sign an internal confidentiality agreement or statement that prohibits or otherwise restricts



**SECTION SEVEN**  
**CONTRACT**

---

or purports to prohibit or restrict the reporting (in accordance with law) of waste, fraud, or abuse to an investigative or law enforcement representative of federal department or agency authorized to receive such information.

26.2.10.2 The foregoing is not intended, and shall not be understood by, to contravene requirements applicable to Standard Form 312 (which relates to classified information). Form 4414 (which relates to sensitive compartmental information), or any other form issued by a federal department or agency governing the nondisclosure of classified information.

26.2.10.3 In accepting this Contract, the Contractor

26.2.10.3.1 represents that it neither requires nor has required internal confidentiality agreements or statements from employees or contractors that currently prohibit or otherwise currently restrict (or purport to prohibit or restrict) employees or contractors from reporting waste, fraud, or abuse as described above; and

26.2.10.3.2 certifies that if it learns or is notified that it is or has been requiring its employees or contractors to execute agreements or statements that prohibit or otherwise restrict (or purport to prohibit or restrict), reporting of waste, fraud, or abuse as described above, it will immediately stop any further obligations of award funds, will provide prompt written notification to the federal agency whom has awarded these grant funds and will resume (or permit resumption of) such obligations only if expressly authorized to do so by that agency.

26.2.10.4 If the Contractor does or is authorized to make subawards (“subgrants”), or engage a procurement contractor to perform services under this Contract:

26.2.10.4.1 it represents that

26.2.10.4.2 it has determined that no other entity that the Contractor’s application proposes may or will receive award funds (whether through a subaward (“subgrant”), procurement contract, or subcontract under a procurement contract) either requires or has required internal confidentiality agreements or statements from employees or contractors that currently prohibit or otherwise currently restrict (or purport to prohibit or restrict) employees or contractors from reporting waste, fraud, or abuse as described above; and

**SECTION SEVEN  
CONTRACT**

---

- 26.2.10.4.3 it has made appropriate inquiry, or otherwise has an adequate factual basis, to support this representation; and
- 26.2.10.4.4 it certifies that if it learns or is notified that any subrecipient contractor or subcontractor entity that receives funds under this Contract is or has been requiring its employees or contractors to execute agreements or statements that prohibit or otherwise restrict (or purport to prohibit or restrict), reporting of waste, fraud, or abuse as described above, the Owner, will immediately stop any further obligations of Contract funds to or by that entity, will provide prompt written notification to the federal agency making this award, and will resume (or permit resumption of) such obligations only if expressly authorized to do so by that agency.
- 26.2.11 Contractor, its affiliates, agents and employees shall not disclose to others any information, documents, reports, data or records provided to, or prepared by, Contractor under this Contract without the prior written approval of the Owner, except as required by the *Pennsylvania Right-to-Know Law, 65 P.S. §§67.101-3104*, or other applicable law or as otherwise provided in this Contract. Any information, documents, reports, data, or records secured by Contractor from the Owner or a third party in connection with the performance of this Contract shall be kept confidential unless disclosure of such information is:
- 26.2.11.1 Approved in writing by the Owner prior to its disclosure; or
- 26.2.11.2 Directed by a court or other tribunal of competent jurisdiction unless the agreement requires prior Owner approval; or
- 26.2.11.3 Required for compliance with federal or state securities laws or the requirements of national securities exchanges; or
- 26.2.11.4 Necessary for purposes of Contractor's internal assessment and review; or
- 26.2.11.5 Deemed necessary by Contractor in any action to enforce the provisions of this Contract or to defend or prosecute claims by or against parties other than the Owner; or
- 26.2.11.6 Permitted by the valid authorization of a third party to whom the information, documents, reports, data or records pertain; or
- 26.2.11.7 Otherwise required by law.
-

**SECTION SEVEN  
CONTRACT**

---

- 26.2.12 Contractor certifies that neither it nor any of its officers, directors, associates, partners, limited partners or individual owners has been officially notified of, charged with, or convicted of any of the following and agrees to immediately notify the Owner agency granting officer in writing if and when it or any officer, director, associate, partner, limited partner or individual owner has been officially notified of, charged with, convicted of, or officially notified of a governmental determination of any of the following:
- 26.2.12.1 Commission of embezzlement, theft, forgery, bribery, falsification or destruction of records, making false statements or receiving stolen property.
  - 26.2.12.2 Commission of fraud or a criminal offense or other improper conduct or knowledge of, approval of or acquiescence in such activities by Contractor or any affiliate, officer, director, associate, partner, limited partner, individual owner, or employee or other individual of entity associated with:
    - 26.2.12.2.1 Obtaining;
    - 26.2.12.2.2 Attempting to obtain; or
    - 26.2.12.2.3 Performing a public grant or subgrant Contractor's acceptance of the benefits derived from the conduct shall be deemed evidence of such knowledge, approval or acquiescence.
  - 26.2.12.3 Violation of federal or state antitrust statutes.
  - 26.2.12.4 Violation of any federal or state law regulating campaign contributions.
  - 26.2.12.5 Violation of any federal or state environmental law.
  - 26.2.12.6 Violation of any federal or state law regulating hours of labor, minimum wage standards or prevailing wage standards; discrimination in wages; or child labor violations.
  - 26.2.12.7 Violation of the *Act of June 2, 1915 (P.L.736, No. 338)*, known as the *Workers' Compensation Act*, 77 P.S. 1 et seq.
  - 26.2.12.8 Violation of any federal and state law prohibiting discrimination in employment, including but not limited to 28 CFR Part 42.
  - 26.2.12.9 Debarment by any agency or department of the federal government or by any other state.

## SECTION SEVEN CONTRACT

---

- 26.2.12.10 Any other crime involving moral turpitude or business honesty or integrity. Contractor acknowledges that the Owner may, in its sole discretion, terminate the contract for cause upon such notification or when the Owner otherwise learns that Contractor has been officially notified, charged or convicted.
- 26.2.13 If this Contract was awarded to Contractor on a non-bid basis, Contractor must, (as required by *Section 1641* of the *Pennsylvania Election Code*) file a report of political contributions with the Secretary of the Commonwealth on or before February 15 of the next calendar year. The report must include an itemized list of all political contributions known to Contractor by virtue of the knowledge possessed by every officer, director, associate, partner, limited partner, or individual owner that has been made by:
- 26.2.13.1 Any officer, director, associate, partner, limited partner, individual owner or members of the immediate family when the contributions exceed as aggregate of one thousand dollars (\$1,000) by any individual during the preceding year; or any employee or members of his immediate family whose political contribution exceeded one thousand dollars (\$1,000) during the preceding year.
- 26.2.13.2 To obtain a copy of the report form, Contractor shall contact the Bureau of Commissioners, elections and Legislation, Division of Campaign Finance and Lobby Disclosure, Room 210, North Office Building, Harrisburg, PA 17120.
- 26.2.14 Contractor shall comply with requirements of the *Lobbying Disclosure Act, 65 Pa.C.S. § 13A01 et seq.*, and the regulations promulgated pursuant to that law. Contractor employee activities prior to or outside of formal Commonwealth procurement communication protocol are considered lobbying and subjects the Contractor employees to the registration and reporting requirements of the law. Actions by outside lobbyists on Contractor's behalf, no matter the procurement stage, are not exempt and must be reported.
- 26.2.15 When Contractor has reason to believe that any breach of ethical standards as set forth in law, the Governor's code of Conduct, or in these provisions has occurred or may occur, including but not limited to contact by a Commonwealth officer or employee which, if acted upon, would violate such ethical standards, Contractor shall immediately notify the Commonwealth granting officer or Commonwealth Inspector General in writing.
- 26.2.16 Contractor, by submission of its bid or proposal and/or execution of this Contract by the submission of any bills, invoices or requests for payment pursuant to the
-

## SECTION SEVEN CONTRACT

---

grant, certifies and represents that it has not violated any of these integrity provisions in connection with the submission of the bid or proposal, during any contract negotiations or during the term of the Contract.

- 26.2.17 Contractor shall cooperate with the Office of Inspector General in its investigation of any alleged Commonwealth employee breach of ethical standards and any alleged Contractor non-compliance with these provisions. Contractor agrees to make identified Contractor employees available for interviews at reasonable times and places. Contractor, upon the inquiry or request of the Office of Inspector General, shall provide, or if appropriate, make promptly available for inspection or copying, any information of any type or form deemed relevant by the Inspector General to Contractor's integrity and compliance with these provisions. Such information may include, but shall not be limited to, Contractor's business or financial records, documents or files of any type or form that refers to or concern this Contract.
- 26.2.18 For violation of any of these Integrity Provisions, the Owner may terminate that and any other contract with Contractor, claim liquidated damages in an amount equal to the value of anything received in breach of these provisions, claim damages for all additional costs and expenses incurred in obtaining another Contractor to complete performance under this Contract, and debar and suspend Contractor from doing business with the Owner. These rights and remedies are cumulative, and the use or non-use of any one shall not preclude the use of all or any other. These rights and remedies are in addition to those the Commonwealth may have under law, statute, regulation or otherwise.
- 26.2.19 For purposes of these Integrity Provisions, the following terms shall have the meanings found in this Clause 26.
- 26.2.19.1 "Confidential information" means information that a) is not already in the public domain; b) is not available to the public upon request; c) is not or does not become generally known to Contractor from a third party without an obligation to maintain its confidentiality; d) has not become generally known to the public through an act or omission of Contractor; or e) has not been independently developed by Contractor without the use of confidential information of the Owner or Commonwealth.
- 26.2.19.2 "Consent" means written permission signed by a duly authorized officer or employee of the Owner or Commonwealth, provided that where the material facts have been disclosed, in writing, by pre-qualification, bid, proposal, or grantual terms, the Owner or Commonwealth shall be deemed to have consented by virtue of execution of this Contract.

**SECTION SEVEN  
CONTRACT**

---

- 26.2.19.3 “Contractor” means the individual or entity that has entered into this Contract with the Owner, including those directors, officers, partners, managers and owners having more than a five percent interest in Contractor.
- 26.2.19.4 “Financial interest” means:
- 26.2.19.4.1 Ownership of more than a five percent interest in any business; or
  - 26.2.19.4.2 Holding a position as an officer, director, trustee, partner, employee or holding any position of management.
- 26.2.19.5 “Gratuity” means tendering, giving or providing anything of more than nominal monetary value including, but not limited to, cash, travel, entertainment, gifts, meals, lodging, loans, subscriptions, advances, deposits of money, services, employment or grants of any kind. The exceptions set forth in the Governor’s Code of Conduct, Executive Order 1980-18, the 4 Pa. Code §7.153(b), shall apply.
- 26.2.19.6 “Immediate family” means a spouse and any unemancipated child.
- 26.2.19.7 “Non-bid basis” means a grant awarded or executed by the Owner with Contractor without seeking bids or proposals from any other potential bidder or offeror.
- 26.2.19.8 “Political contribution” means any payment, gift, subscription, assessment, grant, payment for services, dues, loan, forbearance, advance or deposit of money or any valuable thing, to a candidate for public office or to a political committee, including but not limited to a political action committee, made for the purpose of influencing any election in the Commonwealth of Pennsylvania or for paying debts incurred by or for a candidate or committee before or after any election.

**27. Debarment/Tax Liabilities**

- 27.1 For the purpose of these provisions, the term contractor is defined as any person, including, but not limited to, a bidder, offeror, loan recipient, provider, or subcontractor, who has furnished or seeks to furnish goods, supplies, services, or leased space, or who has performed or seeks to perform construction activity under contract, subcontract, grant or subgrant with the Owner, or with a person under contract, subcontract, grant, or subgrant with the Owner or its state-affiliated entities, and state-related institutions. The term contractor may include a permittee, licensee, or any agency, political subdivision, instrumentality, public authority, or other entity of the Owner.

## SECTION SEVEN CONTRACT

---

- 27.1.1 The Contractor must certify, in writing, for itself and all its subcontractors, that as of the date of its execution of any Owner contract, that neither the Contractor, nor any subcontractors, nor any suppliers are under suspension or debarment by the Commonwealth or any governmental entity, instrumentality, or authority and, if the Contractor cannot so certify, then it agrees to submit, along with the bid/proposal, a written explanation of why such certification cannot be made.
- 27.1.1.1 The Contractor must also certify, in writing, that as of the date of its execution, of any Owner contract it has no tax liabilities or other Owner or Commonwealth obligations.
- 27.1.1.2 The Contractor's obligations pursuant to these provisions are ongoing from and after the effective date of the contract through the termination date thereof. Accordingly, the Contractor shall have an obligation to inform the contracting agency if, at any time during the term of the contract, it becomes delinquent in the payment of taxes, or other Owner or Commonwealth obligations, or if it or any of its subcontractors are suspended or debarred by the Commonwealth, the federal government, or any other state or governmental entity. Such notification shall be made within fifteen (15) days of the date of suspension or debarment.
- 27.1.2 The failure of the Contractor to notify the contracting agency of its suspension or debarment by the Commonwealth, any other state, or the federal government shall constitute an event of default of the contract with the Owner.
- 27.1.3 The Contractor agrees to reimburse the Commonwealth for the reasonable costs of investigation incurred by the Office of State Inspector General for investigations of the Contractor's compliance with the terms of this or any other contract between the Contractor and the Owner, which results in the suspension or debarment of the Contractor. Such costs shall include, but shall not be limited to, salaries of investigators, including overtime; travel and lodging expenses; and expert witness and documentary fees. The Contractor shall not be responsible for investigative costs for investigations that do not result in the Contractor's suspension or debarment.
- 27.1.4 Contractor shall immediately self-report any discovered exclusion of an employee or contractor, either an individual or an entity, to the Bureau of Program Integrity either:
- 27.1.4.1 Via e-mail through the MA Provider Compliance form at the following link:

**SECTION SEVEN  
CONTRACT**

---

[https://forms.office.com/Pages/ResponsePage.aspx?id=QSiOOSgB1U2b bEf8Wpob3qI3pAawcL5FtG\\_Hh\\_QOF81URERZQTJSMjExTEIBSEg5SEtORUc5UVNDTS4u](https://forms.office.com/Pages/ResponsePage.aspx?id=QSiOOSgB1U2b bEf8Wpob3qI3pAawcL5FtG_Hh_QOF81URERZQTJSMjExTEIBSEg5SEtORUc5UVNDTS4u)

- 27.1.4.2 By U.S. mail at the following address:
- Department of Human Services  
Office of Administration  
Bureau of Program Integrity  
Commonwealth of Pennsylvania  
P.O. Box 2675  
Harrisburg, PA 17105-2675
- 27.1.4.3 By fax at: 1-717-772-4655
- 27.1.4.4 Contractor shall copy the Owner on any notice given to the Bureau of Program Integrity in the manner and at the address provided for giving notices to the Owner in this Contract.
- 27.1.5 Contractor shall develop and maintain auditable documentation of screening efforts, including dates the screenings were performed and the source data checked and its date of most recent update.
- 27.1.6 Contractor shall periodically conduct self-audits to determine compliance with this requirement.
- 27.1.7 Contractor shall provide evidence of compliance with these requirements to the Owner within ten (10) days following a request by the Owner.
- 27.1.8 Contractor may obtain a current list of suspended and debarred Commonwealth providers by accessing:
- 27.1.8.1 The Commonwealth of Pennsylvania - Debarment and Suspension List online at the website below:
- <https://www.dgs.internet.state.pa.us/debarmentsearch/debarment/index>
- or contacting the:
- Department of General Services  
Office of Chief Counsel  
603 North Office Building  
Harrisburg, PA 17125
-



## SECTION SEVEN CONTRACT

---

Telephone No: 717-783-6472

Fax No.: 717-787-9138

- 27.1.8.2. The Worker Protection and Labor Law Non-Compliance List online at the website below:

<https://www.dli.pa.gov/Pages/Non-Compliance-List.aspx>

- 27.1.9 It shall be the responsibility of the Contractor to determine and utilize the appropriate site for said database.

### **28. Nondiscrimination/Sexual Harassment Clause**

- 28.1 During the term of the Contract, Contractor agrees as follows:

- 28.1.1 In the hiring of any employee(s) for the manufacture of supplies, performance of work, or any other activity required under the Contract or any contract or subcontract, the Contractor, a subcontractor, or any person acting on behalf of the Contractor shall not, by reason of gender, race, creed or color, discriminate against any citizen of this Commonwealth who is qualified and available to perform the work to which the employment relates.
- 28.1.2 The Contractor or any subcontractor or any person on their behalf shall not in any manner discriminate against or intimidate any of its employees on account of gender, race, creed or color.
- 28.1.3 The Contractor or any subcontractor shall establish and maintain a written sexual harassment policy and shall inform their employees of the policy. The policy must contain a notice that sexual harassment will not be tolerated and employees who practice it will be disciplined.
- 28.1.4 The Contractor or any subcontractor shall not discriminate by reason of gender, race, creed or color against any contractor, subcontractor or supplier who is qualified to perform the work to which the contract relates.
- 28.1.5 The Contractor or any subcontractor shall, within the time periods requested by the Owner, furnish all necessary employment documents and records and permit access to their books, records and accounts by the Owner and the Bureau of Minority and Women Business Opportunities (BMWBO), for the purpose of ascertaining compliance with provisions of this Nondiscrimination/Sexual Harassment Clause.

**SECTION SEVEN  
CONTRACT**

---

28.1.6 The Contractor any contractor or subcontractor shall include the provisions of this Nondiscrimination/Sexual Harassment Clause in every contract or subcontract so that those provisions applicable to contractors or subcontractors will be binding upon each contractor or subcontractor.

28.1.7 The Owner may cancel or terminate the contract and all money due or to become due under the contract may be forfeited for a violation of the terms and conditions of this Nondiscrimination/Sexual Harassment Clause. In addition, Owner may proceed with debarment or suspension and may place the Contractor or subcontractor in the Contractor Responsibility File.

**29. Right to Know Law**

29.1 The Pennsylvania Right-to-Know Law (hereinafter “RTKL”), 65 P.S. §§ 67.101-3104, applies to this Contract.

29.2 Unless the Contractor provides the Owner, in writing, with the name and contact information of another person, the Owner shall notify the provider using the Contractor information provided by the Contractor in this Contract if the Owner needs the Contractor’s assistance in any matter arising out of the RTKL. The Contractor shall notify the Owner in writing of any change in the name or the contact information within a reasonable time prior to the change.

29.3 Upon notification to the Contractor that the Owner has received a request for records under the RTKL related to this Contract that may be in the Contractor’s possession, constituting or alleged to constitute, a public record in accordance with the RTKL (“Requested Information”), the Contractor shall:

29.3.1 Provide the Contractor, within five (5) business days after receipt of the Owner’s written notification, access to, and copies of, any document or information in the Contractor’s possession arising out of this Contract that the Owner reasonably believes is Requested Information and may be a public record under the RTKL; and

29.3.2 Provide such other assistance as the Owner may reasonably request, in order to comply with the RTKL with respect to this Contract.

29.4 If the Contractor considers the Requested Information to include a request for a Trade Secret or Confidential Proprietary Information, as those terms are defined by the RTKL, or information that the Contractor considers exempt from production under the RTKL, the Contractor must notify the Owner and provide within five (5) business days of receiving the Owner’s written notification, a written statement signed by a

## SECTION SEVEN CONTRACT

---

- representative of the Contractor explaining why the requested material is exempt from public disclosure under the RTKL.
- 29.5 The Owner will rely upon the written statement from the Contractor in denying a RTKL request for the Requested Information unless the Owner determines that the Requested Information is clearly not protected from disclosure under the RTKL.
- 29.6 If the Contractor fails to provide the Requested Information within the time period required by these provisions, the Contractor shall indemnify and hold the Owner harmless for any damages, penalties, costs, detriment or harm that the Owner may incur as a result of the Contractor's failure, including any statutory damages assessed against the Owner.
- 29.7 The Owner will reimburse the Contractor for any costs associated with complying with these provisions only to the extent allowed under the fee schedule established by the Office of Open Records or as otherwise provided by the RTKL if the fee schedule is inapplicable.
- 29.8 The Contractor may file a legal challenge to a decision by the Owner to release a record the public with the Office of Open Records, or in the Pennsylvania Courts, however, the Contractor shall indemnify the Owner for any legal expenses incurred by the Owner as a result of such a challenge and shall hold the Owner harmless for any damages, penalties, costs, detriment or harm that the Owner may incur as a result of the Contractor's failure, including any statutory damages assessed against the Owner, regardless of the outcome of such legal challenge. As between the parties, the Contractor agrees to waive all rights or remedies that may be available to it as a result of the Owner's disclosure of Requested Information pursuant to the RTKL.
- 29.9 The Contractor's duties relating to the RTKL are continuing duties that survive the expiration of the Contract and shall continue as long as the Contractor has Requested Information in its possession.

### **30. Worker Protection and Investment**

- 30.1 To the extent applicable, Contractor shall comply with Commonwealth of Pennsylvania Executive Order 2021-06, Worker Protection and Investment, and certify Contractor is in compliance with all applicable Pennsylvania state labor and workforce safety laws including:
- 30.1.1 Construction Workplace Misclassification Act;
- 30.1.2 Employment of Minors Child Labor Act;

**SECTION SEVEN  
CONTRACT**

---

- 30.1.3 Minimum Wage Act;
  - 30.1.4 Prevailing Wage Act;
  - 30.1.5 Equal Pay Law;
  - 30.1.6 Employer to Pay Employment Medical Examination Fee Act;
  - 30.1.7 Seasonal Farm Labor Act;
  - 30.1.8 Wage Payment and Collection Law;
  - 30.1.9 Industrial Homework Law;
  - 30.1.10 Construction Industry Employee Verification Act;
  - 30.1.11 Act 102: Prohibition on Excessive Overtime in Healthcare;
  - 30.1.12 Apprenticeship and Training Act; and,
  - 30.1.13 Inspection of Employment Records Law.
- 30.2 Contractor shall also certify compliance with Unemployment Compensation tax requirements and Workers' Compensation insurance requirements.

**31. Enumeration of Contract Documents**

- 31.1 The Contract Documents, except for modifications issued after execution of this Contract, are enumerated as follows:
  - 31.1.1 This Contract.
  - 31.1.2 The Invitation to Bid #24-08-GR and its Amendments are incorporated into this Contract by reference.
  - 31.1.3 The Supplementary and other conditions of the Contract, if any.
  - 31.1.4 Bid Form.
  - 31.1.5 Payment Bond.
  - 31.1.6 Performance Bond.

**SECTION SEVEN  
CONTRACT**

---

31.1.7 Non-Collusion Affidavit.

31.1.8 Subcontractors List.

31.1.9 Equipment Suppliers List.

31.1.10 Alternates/Substitution List.

31.1.11 Other documents, if any, forming part of the Contract Documents are as follows:  
N/A

31.2 The various documents constituting the Contract Documents and the provisions therein contained are mutually dependent and complementary, and what is called for by any one of the Contract Documents shall be binding as if called for by all of the Contract Documents. All parts of the Contract Documents shall be construed so as to be consistent with each other, if possible, but in the event of conflicts, inconsistencies or discrepancies between and/or within the Contract Documents, or any part thereof, the Contractor shall (1) provide the better quality or greater quantity of the work; or (2) comply with the more stringent requirement, or both, in accordance with the Owner's interpretation

**32. Headings**

All headings included for convenience only and shall not affect any construction or interpretation of this Contract.

**33. Entire Contract**

The governing terms and conditions of this Contract are expressly limited to the terms and conditions contained in this Contract and documents incorporated herein. This Contract constitutes the complete integration of all oral and written documents, is the entire and final Contract between the parties and may be amended only by a written instrument signed by authorized officials of both parties.

With the intent to be legally bound, authorized officials of each party have signed this Contract on the dates written below. Each person signing this Contract represents and warrants that such person is fully authorized to sign and enter into this Contract on behalf of the Contractor named above his or her signature.

**SECTION SEVEN  
CONTRACT**

---

Both parties agree and acknowledge that electronic/facsimile signatures are binding to this Contract.

**County of Berks**

**Contractor**

By: \_\_\_\_\_

By: \_\_\_\_\_

Name (printed): Kelly A. Laubach, CPPB

Name (printed): \_\_\_\_\_

Title: Director of Contracts and Procurement

Title: \_\_\_\_\_

Date: \_\_\_\_\_

Date: \_\_\_\_\_

ATTEST:

ATTEST:

By: \_\_\_\_\_

By: \_\_\_\_\_

Name (printed): George M. Rodrigues

Name (printed): \_\_\_\_\_

Title: Contract Manager

Title: \_\_\_\_\_

**SECTION EIGHT  
BID FORM**

---

BID FORM – ITB #24-08-GR - Wertz Covered Bridge Stair Replacement

County of Berks  
Berks County Services Center  
Controller’s Office, 12<sup>th</sup> Floor  
633 Court Street  
Reading, PA 19603

DATE \_\_\_\_\_

Re: County of Berks  
The following Bid is submitted in response to your Advertisement to Bid.

**This Bid is submitted by:**

Company Name: \_\_\_\_\_

Company Address: \_\_\_\_\_

Main Telephone: \_\_\_\_\_

Main Fax: \_\_\_\_\_

*Communications and questions concerning this bid are to be directed to:*

Contact Name / Title: \_\_\_\_\_

Contact Telephone: \_\_\_\_\_

Fax: \_\_\_\_\_

Contact Email: \_\_\_\_\_

*In the event our company is awarded a contract as a result of the ITB and this bid, the following individual will serve as project liaison/manager:*

Name / Title: \_\_\_\_\_

Office Address: \_\_\_\_\_

Telephone: \_\_\_\_\_

Fax: \_\_\_\_\_

Email: \_\_\_\_\_

---

**SECTION EIGHT  
BID FORM**

---

This Bidder agrees to furnish bonds required by Instructions to Bidders and General Conditions. Bid Security in the amount required by Instructions to Bidders and General Conditions is enclosed. It is agreed that Bid Security shall be forfeited to the addressee if this Bidder does not, within ten (10) days after notification of Award of Contract, enter into a Contract and provide the required bonds and insurance.

This Bidder has carefully examined all CONTRACT DOCUMENTS and the BID DOCUMENTS and certifies that it fully understands the requirements thereof. This Bidder agrees that, after notification of Award of Contract, it will furnish and deliver the materials, tools, equipment, tests, transportation, secure permits and licenses, do and perform labor, superintendence and means of construction, pay fees and do incidental work, and execute, construct and finish the aforesaid in an expeditious, substantial and workmanlike manner; in accordance with the Bid Documents and the Contract Documents to the complete satisfaction and acceptance of the Owner for the price hereinafter stated.

Bidder understands that the Award of Contract will be preconditioned on submittal to the Owner of a Certificate of Insurance, Payment Bond and Performance Bond as outlined in the Instructions to Bidders and General Conditions.

Bidder understands the following supplement to the Bid Form must be submitted concurrent with this bid submission.

- Bid Security Form (Bid Bond)
- Non-Collusion Affidavit
- Sample Certificate of Insurance evidencing limits required herein
- Commonwealth of Pennsylvania Public Works Employment Verification Form for Bidder
- Agreement of Surety
- Worker Protection and Investment Certification Form BOP-2201

Bidder understands the following supplement to the Bid Form must be submitted, if applicable, when directed to do so by the Owner, or Owner's agent.

- Performance Bond
- Payment Bond
- Commonwealth of Pennsylvania Public Works Employment Verification Form for Subcontractors.
- Subcontractors List
- Equipment Suppliers List
- Alternates/Substitution List

Certificate of Insurance evidencing limits and including the additional insured language required herein. The Contractor's General Liability policy shall include the CG2503 Designated Construction Project's General Aggregate Limit or the equivalent.

Bidder's Handwritten Initials \_\_\_\_\_

**BID FORM**

---



**SECTION EIGHT  
BID FORM**

---

This Bid is submitted with the definite understanding that Bids are valid for acceptance by the County of Berks and may not be withdrawn for a period of at least sixty (60) days after the actual date of the opening thereof unless the Award of Contract is delayed due to required approvals of other governmental agencies, or sale of bonds, in which case, Bids shall be irrevocable for one hundred twenty (120) days in compliance with Act 1978-317, approved November 26, 1978.

It is understood that the Owner reserves the right to reject any or all Bids, or part thereof or items therein, and to waive technicalities required for the best interests of the Owner. Omission of any information may be sufficient cause for rejection of this Bid. It is further understood that competency and responsibility of Bidders will receive consideration before the Award of Contract.

The undersigned will not assign its Bid or any of its rights or interests thereunder without the written consent of the Owner.

The Base Bid and other required information are submitted in the spaces provided. Handwritten initials on each page of this Bid Form identify each as a part of this Bid.

**BASE BID**

The sum of \_\_\_\_\_ Dollars  
(\$ \_\_\_\_\_) for the County of Berks Wertz Covered Bridge Stair Replacement Project.

**COST BREAKDOWN**

Total shall equal Base Bid.

Bonds \$ \_\_\_\_\_

Construction Contract \$ \_\_\_\_\_

*\* Cost breakdowns are for administrative purposes only, and will not be used to determine the lowest possible bidder.*

Bidder's Handwritten Initials \_\_\_\_\_

**BID FORM**

---

**SECTION EIGHT  
 BID FORM**

**BASE BID – COST PROPOSAL SUMMARY**

Item No.	Quantity	Item Description	Unit Price	Total Price
1	1	Mobilization/demobilization	\$ _____	\$ _____
2	1	Bonds & Insurance	\$ _____	\$ _____
3	1	Demolition	\$ _____	\$ _____
4	1	Excavation & Grading	\$ _____	\$ _____
5	1	Concrete footings	\$ _____	\$ _____
6	1	Wood framing, decking and guards	\$ _____	\$ _____
7	1	Aluminum handrails	\$ _____	\$ _____

<p><b>TOTAL AMOUNT OF BASE BID</b></p>   <p style="text-align: center;">_____ DOLLARS \$ _____</p>
---

**SECTION EIGHT  
BID FORM**

---

**ALL ITEMS MUST BE BID FOR PROPOSAL TO BE CONSIDERED**

- ❖ For each line item offered, Bidders shall show both the unit price and extended price. In case of a discrepancy between the unit price and extended price, the unit price will be presumed to be correct, and the extended price shall be corrected accordingly
- ❖ All Base Bid items **MUST** be bid. (Component Item Schedules for each location, which together constitute the Base Bid Summary, are included below for information purposes.)
- ❖ A **Bid Bond** in the amount of ten percent (10%) of the total amount of bid **MUST** be submitted with your bid.
- ❖ A **Performance Bond** and a **Payment Bond** in the amounts of one hundred percent (100%) of the Total Amount Bid **MUST** be submitted by the successful bidder within ten (10) days from the bid award date (refer to Section One, Paragraph 13).
- ❖ A one (1) year **Warranty** **MUST** be submitted by the successful bidder within ten (10) days from the bid award date (refer to Section One, Paragraph 38).

**SECTION EIGHT  
BID FORM**

---

**ALTERNATES**

The following listed alternate prices shall be filled in and submitted with the Bid Form. It is agreed that all Work to be performed under accepted alternate prices shall conform to the applicable Contract Documents, and shall include all Work in connection with or consequent to the alternate price Work to produce a complete installation.

Alternate prices shall be all inclusive of the cost of materials, Work, profit, supervision, administration and any and all other costs in connection therewith for Work in place and accepted or omitted as the case may be, and shall hold for the same period as the Bid.

Bidder's Handwritten Initials \_\_\_\_\_

**BID FORM**

The undersigned hereby proposes the following prices for Alternates, the selection of which shall be at the Owner's option:

A. \_\_\_\_\_.  
1. \_\_\_\_\_.  
Add/(Deduct) \$ \_\_\_\_\_

B. \_\_\_\_\_.  
1. \_\_\_\_\_.  
Add/(Deduct) \$ \_\_\_\_\_

**UNIT COSTS**

The provisions of the Contract Documents shall apply to all work performed in accordance with the Unit Prices described herein. Unit Prices shall be used, where applicable, to make adjustments to the cost of the Work of this Contract due to changes to the Work required by the Drawings and Specifications. ALL Unit Prices shall be complete in place prices and include costs for all necessary material, delivery, installation, overhead and profit, and shall remain firm for the period of the contract. General Conditions, as required by the drawings and Divisions 0 and 1 of the specifications, shall NOT be included in Unit Prices. Unit Prices listed are for additions or deletions to the work and shall remain firm for the full duration of the contract.

Bidder's Handwritten Initials \_\_\_\_\_

**BID FORM**

---

**SECTION EIGHT  
BID FORM**

---

**ADDENDA**

The Bidder acknowledges receipt of Addenda listed below which have been issued during the bidding period and agrees that said Addenda shall become part of the Contract (Bidder shall list numbers and dates of Addenda received).

No. \_\_\_\_\_ Date \_\_\_\_\_ No. \_\_\_\_\_ Date \_\_\_\_\_  
No. \_\_\_\_\_ Date \_\_\_\_\_ No. \_\_\_\_\_ Date \_\_\_\_\_

**Authorized signature of Bidder**

Please check the appropriate category:

\_\_\_\_\_ Sole Proprietorship                      \_\_\_\_\_ Partnership  
\_\_\_\_\_ Pennsylvania Corporation              \_\_\_\_\_ Foreign Corporation Registered in PA

The undersigned hereby certifies that this Bid is genuine and not sham, collusive or fraudulent or made in the interest of or on behalf of any person, firm, or corporation not herein named; and that the undersigned has not, directly or indirectly, induced or solicited any Bidder to submit a sham Bid, or any other person, firm or corporation from bidding, and that the undersigned has not, in any manner, sought by collusion to secure for himself any advantage over any other Bidder.

COMPANY NAME \_\_\_\_\_

FEDERAL ID# \_\_\_\_\_

STREET ADDRESS                      PO BOX                      CITY                      STATE                      ZIP

TELEPHONE # \_\_\_\_\_ FAX # \_\_\_\_\_

Witness or Attest:

\_\_\_\_\_  
An Officer, if Bidder is corporation, if not corporation, any competent adult

\_\_\_\_\_  
Owner, Partner, or President/Vice President\*

\* Bidder to circle appropriate term.

**SECTION NINE  
SUBCONTRACTORS LIST**

---

**COUNTY OF BERKS**

**SUBCONTRACTORS LIST**

Herewith is the List of Subcontractors who will perform the Work on the Project referenced in the Bid submitted by:

(Bidder)

\_\_\_\_\_

to

(Owner)

\_\_\_\_\_

dated \_\_\_\_\_ and which is an integral part of the Bid Form.

The following Work will be performed or provided by the named Subcontractors and coordinated by us:

**SECTION OF WORK  
(SPEC SECTION)**

**SUBCONTRACTOR / TELEPHONE NO.**

\_\_\_\_\_  
\_\_\_\_\_  
\_\_\_\_\_  
\_\_\_\_\_  
\_\_\_\_\_  
\_\_\_\_\_  
\_\_\_\_\_  
\_\_\_\_\_  
\_\_\_\_\_  
\_\_\_\_\_  
\_\_\_\_\_  
\_\_\_\_\_

\_\_\_\_\_  
\_\_\_\_\_  
\_\_\_\_\_  
\_\_\_\_\_  
\_\_\_\_\_  
\_\_\_\_\_  
\_\_\_\_\_  
\_\_\_\_\_  
\_\_\_\_\_  
\_\_\_\_\_  
\_\_\_\_\_  
\_\_\_\_\_

**SECTION TEN  
EQUIPMENT SUPPLIERS LIST**

---

**COUNTY OF BERKS**

**EQUIPMENT SUPPLIERS LIST**

Herewith is the List of the Suppliers of Equipment to be installed in the Project referenced in the Bid submitted by:

(Bidder)

\_\_\_\_\_

to

(Owner)

\_\_\_\_\_

dated \_\_\_\_\_ and which is an integral part of the Bid Form.

EQUIPMENT  
COMPONENTS OR  
ITEMS

SUPPLIER / TELEPHONE NO.

\_\_\_\_\_  
\_\_\_\_\_  
\_\_\_\_\_  
\_\_\_\_\_  
\_\_\_\_\_  
\_\_\_\_\_  
\_\_\_\_\_  
\_\_\_\_\_  
\_\_\_\_\_  
\_\_\_\_\_  
\_\_\_\_\_

\_\_\_\_\_  
\_\_\_\_\_  
\_\_\_\_\_  
\_\_\_\_\_  
\_\_\_\_\_  
\_\_\_\_\_  
\_\_\_\_\_  
\_\_\_\_\_  
\_\_\_\_\_  
\_\_\_\_\_  
\_\_\_\_\_





**SECTION TWELVE  
NON-COLLUSION AFFIDAVIT**

---

**COUNTY OF BERKS**

NON-COLLUSION AFFIDAVIT

CONTRACT NO. \_\_\_\_\_

Commonwealth of Pennsylvania :  
: s.s.  
County of \_\_\_\_\_ :

I state that I am \_\_\_\_\_ of \_\_\_\_\_ the Bidder  
(Title) (Name of My Company),  
that submitted the attached Bid and that I am authorized to make this affidavit on behalf of my  
company, its owners, directors, and officers. I am the person responsible in my company for the  
price(s) and the amount of this Bid.

**I state that:**

(1) The price(s) and amount of this Bid have been arrived at independently and without  
consultation, communication or agreement by the Bidder, any of its sureties, agents,  
representatives, owners, employees, or parties in interest with any other contractors, bidders,  
potential bidders or any other sureties, agents, representatives, owners, employees or parties in  
interest of any other contractors, bidders or potential bidders. The price(s) quoted in the attached  
Bid are fair and proper and are not tainted by any collusion, conspiracy, connivance or unlawful  
agreement on the part of the Bidder or any of its sureties, agents, representatives, owners,  
employees, or parties in interest, including this affidavit.

(2) Neither the price(s) nor the amount of this Bid, and neither the approximate price(s)  
nor approximate amount of this Bid, have been disclosed to any other company or person who is  
a bidder, potential bidder or a surety, agent, representative, owner, employee or party in interest of  
any other contractor, bidder or potential bidder, and they will not be disclosed before opening bid.

(3) No attempt has been made or will be made to induce any company or person to  
refrain from bidding on this contract, or to submit a Bid higher than this Bid, or to submit any  
collusive or intentionally high or non-competitive Bid or other form of complementary Bid.

(4) The Bid of my company is made in good faith and not pursuant to any agreement  
or discussion with, or inducement from, any bidder, potential bidder or a surety, agent,  
representative, owner, employee or party in interest of any other contractor, bidder or potential  
bidder to submit a complementary or other non-competitive Bid.

(5) \_\_\_\_\_, its affiliates, subsidiaries, officers, directors, and  
(Name of My Company)

**SECTION TWELVE  
NON-COLLUSION AFFIDAVIT**

---

employees are not currently under investigation by any governmental agency and have not in the last three (3) years been convicted or found liable for any act prohibited by State or Federal law in any jurisdiction, involving conspiracy or collusion with respect to bidding on any public contract, except as follows:

I state that \_\_\_\_\_ understands and acknowledges that the  
(Name of My Company)  
above representations are material and important, and will be relied on by the County of Berks in awarding the contract(s) for \_\_\_\_\_ which this Bid is submitted.

I understand and my company understands that any misstatement in this affidavit is and shall be treated as fraudulent concealment from the County of Berks of true facts relating to the submission of Bids for this contract.

\_\_\_\_\_  
(Name and Position in Company)

**SWORN TO AND SUBSCRIBED  
BEFORE ME THIS \_\_\_\_ DAY  
OF \_\_\_\_\_, 2024**

\_\_\_\_\_  
Notary Public  
My Commission Expires:

**SECTION THIRTEEN  
AGREEMENT OF SURETY**

---

(Note: This Agreement shall be properly executed and must accompany the Certified Check, Bank Cashier's Check, Trust Company Treasurer's Check or Bid Bond, whichever is furnished as Bid Security.)

KNOW ALL MEN BY THESE PRESENTS, that we \_\_\_\_\_, as Surety, a corporation existing under the laws of the State of \_\_\_\_\_, and authorized to transact business in the Commonwealth of Pennsylvania, hereby agree to execute within the time limit specified in the Contract Documents, the Performance Bond and Payment Bond in the forms and in the amounts required for the faithful performance and proper fulfillment of the \_\_\_\_\_ Construction Contract for the Wertz Covered Bridge Stair Replacement Project on behalf of

\_\_\_\_\_  
(Name of Contractor)

hereinafter called the Bidder, provided that the above Contract be awarded to the Bidder within sixty (60) days after the date of opening of Bids or otherwise as set forth in the Instructions to Bidders, and the Surety further agrees that should the Surety, after notification of intent to make such award, omit or refuse to execute the required bonds, then the Surety shall pay to the Obligee the difference between the amount of the Principal's accepted Bid and any higher amount for which the Obligee may contract for the required work, as well as any advertising, Architect's, legal and other expenses incurred by the Obligee by reason of the default; provided, however, that the obligations of the Surety hereunder shall not exceed the amount of this Bid Security together with interest.

\_\_\_\_\_  
WITNESS

CORPORATE SURETY

\_\_\_\_\_  
DATE

\_\_\_\_\_  
SIGNATURE (Affix Corporate Seal)

\_\_\_\_\_  
ATTORNEY-IN-FACT

**SECTION FOURTEEN  
LIST OF STATUTES**

---

**PENNSYLVANIA STATUTES**

I. Purdon's Statutes – Title 3 (Agriculture)

Pennsylvania Fertilizer Act, Act of Dec. 13, 2001 (P.L. 876, No. 97 § 1), 3 Pa.C.S.A. § 6701 et seq.

Pennsylvania Soil and Plant Amendment Act, Act of Dec. 13, 2001 (P.L. 876, No. 97 § 1), 3 Pa.C.S.A. § 6901 et seq.

Pennsylvania Pesticide Control Act of 1973, Act of March 1, 1974 (P.L. 90, No. 24), as amended, 3 P.S. 111.21 et seq.

Agricultural Liming Materials Act, Act of March 17, 1978 (P.L. 15, No. 9), as amended, 3 P.S. 132-1 et seq.

Noxious Weed Control Law, Act of April 7, 1982 (P.L. 228, No. 74), as amended, 3 P.S. 255.1 et seq.

Pennsylvania Plant Pest Act of 1992, Act of December 16, 1992 (P.L. 1228, No. 162, § 1), as amended, 3 P.S. 258.1 et seq.

Soil Conservation Law, Act of May 15, 1945 (P.L. 547, § 1), as amended, 3 P.S. 849 et seq.

(Relating to Weather Modification), Act of January 19, 1968 (P.L. (1967) 1024, § 1), as amended, 3 P.S. 1101 et seq.

II. Purdon's Statutes – Title 16 (Counties)

(Relating to Land Use), Act of January 13, 1966 (P.L. (1965) 1292, § 1), as amended, 16 P.S. 11941 et seq.

III. Purdon's Statutes – Title 18 (Crimes and Offenses)

The Crimes Code, Act of December 6, 1972 (P.L. 1482, No. 334), as amended, 18 Pa.C.S.A. 101 et seq.

IV. Purdon's Statutes – Title 30 (Fish)

The Fish and Boat Code, Act of October 16, 1980 (P.L. 996, No. 175), as amended, 30 Pa.C.S.A. 101 et seq.

---

**SECTION FOURTEEN  
LIST OF STATUTES**

---

V. Purdon's Statutes – Title 32 (Forests, Waters and State Parks)

(Relating to Water Power and Water Supply Permits), Act of June 14, 1923 (P.L. 704, § 1), as amended, 32 P.S. 591 et seq.

Water Well Drillers License Act, Act of May 29, 1956 (P.L. (1955) 1840, § 1), as amended, 32 P.S. 645.1 et seq.

(Relating to Flood Control), Act of August 7, 1936 (P.L. 106, 1<sup>st</sup> Ex. Sess., No. 46), as amended, 32 P.S. 653 et seq.

Flood Plain Management Act, Act of October 4, 1978 (P.L. 851, No. 166), as amended, 32 P.S. 679.101 et seq.

Storm Water Management Act, Act of October 4, 1978 (P.L. 864, No. 167), as amended, 32 P.S. 680.1 et seq.

Dam Safety and Encroachments Act, Act of November 26, 1978 (P.L. 1375, No. 325), as amended, 32 P.S. 693.1 et seq.

(Relating to Stream Clearance), Act of June 5, 1947 (P.L. 422, § 1), as amended, 32 P.S. 701 et seq.

(Relating to Potomac River Pollution), Act of May 29, 1945 (P.L. 1134, § 1), as amended, 32 P.S. 741 et seq. *Repealed in Part.* Section 4 of 1981, May 1, P.L. 22 No. 9, repeals this section to “the extent it required one of the members of the Interstate Commission on the Potomac River Basin to be a member of the Pennsylvania Commission on Interstate Cooperation.”

(Relating to Schuylkill River Pollution), Act of June 4, 1945 (P.L. 1383, § 1), as amended, 32 P.S. 751.1 et seq.

(Relating to Delaware River Pollution), Act of April 19, 1945 (P.L. 272, § 1), as amended, 32 P.S. 815.31 et seq.

Delaware River Basin Compact, Act of July 7, 1961 (P.L. 518, §§ 1 to 3), as amended, 32 P.S. 815.101 et seq.

Ohio River Valley Water Sanitation Compact, Act of April 2, 1945 (P.L. 103, § 1), as amended, 32 P.S. 816.1 et seq.

**SECTION FOURTEEN**  
**LIST OF STATUTES**

---

Great Lakes Protection Fund Act, Act of July 6, 1989 (P.L. 215, No. 34), as amended, 32 P.S. 817.11 et seq.

Brandywine River Valley Compact, Act of September 9, 1959 (P.L. 848, § 1), as amended, 32 P.S. 818 et seq.

Wheeling Creek Watershed Protection and Flood Prevention District Compact, Act of August 2, 1967 (P.L. 189, § 1), as amended, 32 P.S. 819.1 et seq.

Susquehanna River Basin Compact, Act of July 17, 1968 (P.L. 368, No. 181), as amended, 32 P.S. 820.1 et seq.

Scenic Rivers Act, as amended, 32 P.S. 820.21 et seq.

Chesapeake Bay Commission Agreement, Act of June 25, 1985 (P.L. 64, No. 25), as amended, 32 P.S. 820.11 et seq.

(Relating to Preservation and Acquisition of Land for Open Space Uses), Act of January 19, 1968 (P.L. (1967) 992, § 1), as amended, 32 P.S. 5001 et seq.

Land and Water Conservation and Reclamation Act, Act of January 19, 1968 (P.L. (1967) 996, § 2), as amended, 32 P.S. 5101 et seq.

Bluff Recession and Setback Act, Act of May 13, 1980 (P.L. 122, No. 48), as amended, 32 P.S. 5201 et seq.

Wild Resource Conservation Act, Act of June 23, 1982 (P.L. 597, No. 170), as amended, 32 P.S. 5301 et seq.

Cave Protection Act, Act of November 21, 1990 (P.L. 539, No. 133), as amended, 32 P.S. 5601 et seq.

Rails to Trails Act, Act of December 18, 1990 (P.L. 748, No. 188), as amended, 32 P.S. 5611 et seq.

VI. Purdon's Statutes - Title 34 (Game)

The Game and Wildlife Code, Act of July 8, 1986 (P.L. 442, No. 93), as amended, 34 Pa.C.S.A. 101 et seq.

VII. Purdon's Statutes – Title 35 (Health and Safety)

**SECTION FOURTEEN**  
**LIST OF STATUTES**

---

(Relating to Public Eating and Drinking Places), Act of May 23, 1945 (P.L. 926, § 1), as amended, 35 P.S. 655.1 et seq. *Repealed in Part.* Section 6(b) of Act 1994, Dec. 12, P.L. 903, No. 131, repealed this section in so far as it is inconsistent with said act (3 Pa.C.S.A. § 6501 et seq.).

The Public Bathing Law, Act of June 23, 1931 (P.L. 899, § 1), as amended, 35 P.S. 672 et seq.

The Clean Streams Law, Act of June 22, 1937 (P.L. 1987), as amended, 35 P.S. 691.1 et seq.

(Related to Commonwealth Contribution to Cost of Abating Pollution) Act of August 20, 1953 (P.L. 1217), as amended, 35 P.S. 701 et seq.

(Related to the Protection of Public Water Supply), Act of June 22, 1937 (P.L. 1987, Art. I, § 1), as amended, 35 P.S. 691.1 et seq.

Pennsylvania Safe Drinking Water Act, Act of May 1, 1984 (P.L. 206, No. 43), as amended, 35 P.S. 721.1 et seq.

Phosphate Detergent Act, Act of July 5, 1989 (P.L. 166, No. 31), as amended, 35 P.S. 722.1 et seq.

Plumbing System Lead Ban and Notification Act, Act of July 6, 1989 (P.L. 207, No. 33), as amended, 35 P.S. 723.1 et seq.

Pennsylvania Sewage Facilities Act, Act of January 24, 1966 (P.L. (1965) 1535, § 1), as amended, 35 P.S. 750.1 et seq. *Repealed in Part.* Section 15 of Act 1990, July 1, P.L. 277, No. 67, repealed this section in so far as it relates to fee payments.

Publicly Owned Treatment Works Penalty Law, Act of March 26, 1992 (P.L. 23, No. 9), as amended, 35 P.S. 752.1 et seq.

Pennsylvania Solid Waste-Resource Recovery Development Act, Act of July 20, 1974 (P.L. 572, No. 198), as amended, 35 P.S. 755.1 et seq.

(Related to Pollution from Abandoned Mines), Act of December 15, 1965 (P.L. 1075, § 1), as amended, 35 P.S. 760.1 et seq.

Sewage System Cleaner Control Act, Act of May 28, 1992 (P.L. 249, No. 41), as amended, 35 P.S. 770.1 et seq.

**SECTION FOURTEEN**  
**LIST OF STATUTES**

---

(Related to Camp Regulation), Act of November 10, 1959 (P.L. 1400, § 1), as amended, 35 P.S. 3001 et seq.

Air Pollution Control Act, Act of January 8, 1960 (P.L. (1959) 2119, § 1), as amended, 35 P.S. 4001 et seq.

(Related to Noise Pollution), Act of June 2, 1988 (P.L. 452, No. 74), as amended, 35 P.S. 4501 et seq.

Pennsylvania Solid Waste Management Act, Act of July 7, 1980 (P.L. 380, No. 97), as amended, 35 P.S. 6018.101 et seq. *Repealed in Part.* Section 905(b) of Act 1988, Feb. 9, P.L. 31, No. 12, § 101, the Low-Level Radioactive Waste Disposal Act (35 P.S. § 7130.101 et seq.), repealed this section insofar as it is inconsistent with said act.

(Related to Infectious and Chemotherapeutic Waste Disposal), Act of July 13, 1988 (P.L. 525, No. 93), as amended, 35 P.S. 6019.1 et seq.

Hazardous Sites Cleanup Act, Act of October 18, 1988 (P.L. 756, No. 108), as amended, 35 P.S. 6020.101 et seq.

Storage Tank and Spill Prevention Act, Act of July 6, 1989 (P.L. 169, No. 32), as amended, 35 P.S. 6021.101 et seq.

Hazardous Material Emergency Planning and Response Act, Act of December 7, 1990 (P.L. 639, No. 1650), as amended, 35 P.S. 6022.101 et seq.

Oil Spill Responder Liability Act, Act of June 11, 1992 (P.L. 303, No. 52), as amended, 35 P.S. 6023.1 et seq.

Land Recycling and Environmental Remediation Standards Act, Act of May 19, 1995 (P.L. 4, No. 2), as amended, 35 P.S. 6026.101 et seq.

Radiation Protection Act, Act of July 10, 1984 (P.L. 688, No. 147, § 101), as amended, 35 P.S. 7110.101 et seq. *Repealed in Part.* Section 17(b) of Act 1992, Dec. 18, P.L. 1638, No. 180, provides that this section is repealed insofar as it is inconsistent with said act.

Low-Level Radioactive Waste Disposal Act, Act of February 9, 1988 (P.L. 31, No. 12, § 101), as amended, 35 P.S. 7130.101 et seq.

Pennsylvania Uniform Construction Code, as amended by S.B. 1139, Session of 2004, 35 P.S. 7210.301-7210.304



**SECTION FOURTEEN  
LIST OF STATUTES**

---

Pennsylvania Worker and Community Right-to-Know Act, Act of October 5, 1984 (P.L. 734, No. 159), as amended, 35 P.S. 7301 et seq.

VIII. Purdon's Statutes – Title 36 (Highways and Bridges)

State Highway Law, Act of June 1, 1945 (P.L. 1242, art. I, § 101), as amended, 36 P.S. 670-101 et seq. *Repealed in Part.* Section 4 of Act 1985, July 3, P.L. 159, No. 43 repealed this act insofar as it is inconsistent with said act.

(Related to Junkyards Along Highways), Act of July 28, 1966 (P.L. 91, § 1, Sp. Sess.), as amended, 36 P.S. 2719.1 et seq.

Highway Vegetation Control Act, Act of December 20, 1983 (P.L. 293, No. 79), as amended, 36 P.S. 2720.1 et seq.

IX. Purdon's Statutes – Title 37 (Historical and Museums)

History Code, Act of May 26, 1988 (P.L. 414, No. 72, § 1), as amended, 37 Pa.C.S.A. 101 et seq.

Pennsylvania Historic Preservation Act, as amended, 37 Pa. C.S.A. 501, et seq.

X. Purdon's Statutes – Title 43 (Labor)

(Related to General Safety), Act of May 18, 1937 (P.L. 654, § 1), as amended, 43 P.S. 25-1 et seq.

Apprenticeship and Training Act, Act No. 304, P.L. 604, as amended, 43 P.S. 90.1 et seq.

Pennsylvania Prevailing Wage Act (Act No. 442 of 1961, P.L. 987, amended by Act 342 of 1963, P.L. 653), as amended, 43 P.S. 165-1 et seq.

Pennsylvania Human Relations Act, Act 222 of October 27, 1955, P.L. 744, as amended, 43 P.S. 951 et seq.

Public Employee Relations Act, as amended, 43 P.S. 1101.201 et seq.

Seasonal Farm Labor Act, Act of June 23, 1978 (P.L. 537, No. 93, § 101), as amended, 43 P.S. 1301.101 et seq.

XI. Purdon's Statutes – Title 52 (Mines and Mining)

---

**SECTION FOURTEEN**  
**LIST OF STATUTES**

---

The Coal Mine Sealing Act of 1947, Act of June 30, 1947 (P.L. 1177, § 1), as amended, 52 P.S. 28.1 et seq.

Coal Refuse Disposal Control Act, Act of September 24, 1968 (P.L. 1040, No. 318, § 1), as amended, 52 P.S. 30.51 et seq.

(Related to Coal Land Improvement), Act of July 19, 1965 (P.L. 216, No. 117, § 1), as amended, 52 P.S. 30.101 et seq.

(Related to Mine Fires and Subsidence), Act of April 3, 1968 (P.L. 92, No. 42), as amended, 52 P.S. 30.201 et seq.

Pennsylvania Anthracite Coal Mine Act, Act of November 10, 1965 (P.L. 721, No. 346, art. I, § 101), as amended, 52 P.S. 70-101 et seq.

(Related to Discharge of Coal into Streams), Act of June 27, 1913 (P.L. 640, § 1), as amended, 52 P.S. 631 et seq.

(Related to Caving-In, Collapse, Subsidence), Act of May 27, 1921 (P.L. 1198, § 1), as amended, 52 P.S. 661 et seq.

(Related to Subsidence), Act of September 20, 1961 (P.L. 1538, § 1), as amended, 52 P.S. 672.1 et seq.

Anthracite Strip Mining and Conservation Act, Act of June 27, 1947 (P.L. 1095, § 2), as amended, 52 P.S. 681.1 et seq. *Repealed in Part.* Section 16 of Act 1971, Nov. 30, P.L. 554, No. 147, provided that this section repealed insofar as it is inconsistent with Act No. 147.

(Related to Control and Drainage of Water from Coal Formations), Act of July 7, 1955 (P.L. 258, § 1), as amended, 52 P.S. 682 et seq.

Pennsylvania Bituminous Coal Mine Act, Act of July 17, 1961 (P.L. 659, art. I, § 101), as amended, 52 P.S. 701-101 et seq.

(Related to Abandoned Mines), Act of May 7, 1935 (P.L. 141, § 1), as amended 52 P.S. 809 et seq.

(Related to Maps and Plans of Mines), Act of June 15, 1911 (P.L. 954, § 1), as amended, 52 P.S. 823.

Surface Mining Conservation and Reclamation Act, Act of May 31, 1945 (P.L. 1198, § 1), as amended, 52 P.S. 1396.1 et seq. *Repealed in Part.* Section 27 of Act 1984, Dec. 19,

---

**SECTION FOURTEEN  
LIST OF STATUTES**

---

P.L. 1093, No. 219, provides that, except as provided in § 3034 of this title, this section “is repealed to the extent that it applies to the surface mining of minerals other than bituminous and anthracite coal.”

The Bituminous Mine Subsidence and Land Conservation Act, Act of April 27, 1966 (P.L. 31, § 1, 1<sup>st</sup> Sp. Sess.), as amended, 52 P.S. 1406.1 et seq.

(Related to Cave-in or Subsidence of Surface Above Mines), Act of July 2, 1937 (P.L. 2787, § 1), as amended, 52 P.S. 1407 et seq.

(Related to Coal Stripping), Act of June 18, 1941 (P.L. 133, § 1), as amended, 52 P.S. 1471 et seq.

(Related to Coal Under State Lands), Act of June 1, 1933 (P.L. 1409, § 1), as amended, 52 P.S. 1501 et seq.

(Related to Mining Safety Zones), Act of December 22, 1959 (P.L. 1994, § 1), as amended, 52 P.S. 3101 et seq.

(Related to Coal Mine Subsidence Insurance Fund), Act of August 23, 1961 (P.L. 1068, § 1), as amended, 52 P.S. 3201 et seq.

Interstate Mining Compact, Act of May 5, 1966, (P.L. 40, Sp. Sess. No. 1, § 1), as amended, 52 P.S. 3251 et seq.

Noncoal Surface Mining Conservation and Reclamation Act, Act of December 19, 1984 (P.L. 1093, No. 219, § 1), as amended, 52 P.S. 3301 et seq.

XII. Purdon’s Statutes – Title 53 (Municipal Corporation)

Municipal Waste Planning, Recycling and Waste Reduction Act, Act of July 28, 1988 (P.L. 556, No. 101), as amended, 53 P.S. 4000.101 et seq.

Pennsylvania Municipalities Planning Code, as amended, 53 P.S. 10101 et seq.

XIII. Purdon’s Statutes – Title 58 (Oil and Gas)

Oil and Gas Conservation Law, Act of July 25, 1961 (P.L. 825), as amended, 58 P.S. 401 et seq.

Pennsylvania Used Oil Recycling Act, Act of April 9, 1982 (P.L. 314, No. 89), as amended, 58 P.S. 471 et seq.

**SECTION FOURTEEN  
LIST OF STATUTES**

---

Coal and Gas Resource Coordination Act, Act of December 18, 1984 (P.L. 1069, No. 214), as amended, 58 P.S. 501 et seq.

Oil and Gas Act, Act of December 19, 1984 (P.L. 1140, No. 223, § 101), as amended, 58 P.S. 601.101 et seq. *Repealed in Part.* Section 4 of Act 1985, July 11, P.L. 232, No. 57, repealed insofar as it is inconsistent with said act.

XIV. Purdon's Statutes – Title 62 (Procurement)

Pennsylvania Prompt Pay Act, 62 Pa. C.S.A. 3931 et seq.

XV. Purdon's Statutes - Title 63 (Professions and Occupations)

Sewage Treatment Plant and Waterworks Operators' Certification Act, Act of November 18, 1968 (P.L. 1052, No. 322), as amended, 63 P.S. 1001 et seq.

XVI. Purdon's Statutes – Title 64 (Public Lands)

Pennsylvania Appalachian Trail Act, Act of April 28, 1978 (P.L. 87, No. 41), as amended, 64 P.S. 801 et seq.

XVII. Purdon's Statutes – Title 65 (Public Officers)

The Right-To-Know Law, as amended, 65 P.S. 67.101 et seq.

XVIII. Purdon's Statutes – Title 71 (State Government)

The Administrative Code of 1929, Act of April 9, 1929 (P.L. 177, No. 175), as amended, 71 P.S. 51 et seq.

Conservation and Natural Resources Act, Act of June 28, 1995 (P.L. 89, No. 18), as amended, 71 P.S. 1340.101 et seq.

XIX. Purdon's Statutes – Title 72 (Taxation and Fiscal Affairs)

Project 70 Land Acquisition and Borrowing Act, Act of June 22, 1964 (P.L. 131, Sp. Sess. No. 8), as amended, 72 P.S. 3946.1 et seq.

(Related to Pollution Control Devices), Act of March 4, 1971 (P.L. 6, No. 2, § 602.1, added 1971, Aug. 31, P.L. 362, No. 93, § 6), as amended, 72 P.S. 7602.1 et seq.

XX. Purdon's Statutes – Title 73 (Trade and Commerce)

---

**SECTION FOURTEEN  
LIST OF STATUTES**

---

(Related to Explosives), Act of July 1, 1937 (P.L. 2681), as amended, 73 P.S. 151 et seq. *Suspended in Part.* This section is suspended insofar as it is in conflict with the provisions of Reorganization Plan No. 8 of 1981. *See 71 P.S. § 751-35.*

(Related to Explosives), Act of July 10, 1957 (P.L. 685), as amended, 73 P.S. 164 et seq. *Suspended in Part.* This section is suspended insofar as it is in conflict with the provisions of Reorganization Plan No. 8 of 1981. *See 71 P.S. § 751-35.*

(Related to Black Powder), Act of May 31, 1974 (P.L. 304, No. 96), as amended, 73 P.S. 169 et seq.

(Related to Excavation and Demolition), Act of December 10, 1974 (P.L. 852, No. 287), as amended, 73 P.S. 176 et seq.

Site Development Act, Act of May 6, 1968 (P.L. 117, No. 61), as amended, 73 P.S. 361 et seq.

Steel Products Procurement Act, Act of March 3, 1978 (P.L. 6, No. 3), as amended, 73 P.S. 1881, et seq.

XXI. Purdon's Statutes – Title 75 (Vehicles)

Vehicle Code, Act of June 17, 1976 (P.L. 162, No. 81), as amended, 75 Pa.C.S.A. 101 et seq.

Snowmobile Law, Act of June 17, 1976 (P.L. 162, No. 81), as amended, 75 Pa.C.S.A. 7701 et seq.

(Related to Hazardous Materials Transport), Act of June 30, 1984 (P.L. 473, No. 99), as amended, 75 Pa.C.S.A. 8301 et seq.

XXII. Purdon's Statutes – Title 77 (Workmen's Compensation)

Pennsylvania Workmen's Compensation Act, Act of June 2, 1915 (P.L. 736), as amended, 77 P.S. 1 et seq.

Pennsylvania Occupational Disease Act, Act of June 21, 1939 (P.L. 566, No. 284), as amended, 77 P.S. 1201 et seq.

XXIII. Pennsylvania Constitution – Article 1, Section 27 (Adopted May 18, 1971).

**SECTION FOURTEEN  
LIST OF STATUTES**

---

**FEDERAL STATUTES**

Acid Precipitation Act of 1980 (42 U.S.C. 8901-8912)

Act to Prevent Pollution from Ships (33 U.S.C. 1901-1915)

Americans with Disabilities Act (42 U.S.C. 12101-12213 and 47 U.S.C. 225 and 611)

Agricultural Act of 1970 (16 U.S.C. 1501-1510)

Asbestos Hazard Emergency Response Act of 1986 (see Toxic Substances Control Act Sections 201-214 (15 U.S.C. 2641-2656))

Atomic Energy Act of 1954 (42 U.S.C. 2014, 2021, 2021a, 2022, 2111, 2113, 2114)

Clean Air Act (42 U.S.C. 7401-7642)

Clean Water Act (see Federal Water Pollution Control Act)

Coastal Wetlands Planning, Protection and Restoration Act (16 U.S.C. 3951-3956)

Coastal Zone Management Act of 1972 (16 U.S.C. 1451-1466)

Community Environmental Response Facilitation Act (42 U.S.C. 9620 note)

Comprehensive Environmental Response, Compensation, and Liability Act of 1980 (42 U.S.C. 9601-9675)

Educate America Act of 1994, as amended from time to time, including, without limitation the Pro-Children Act of 1994 (20 U.S.C. 6081 *et seq.*)

Emergency Planning and Community Right-to-Know Act of 1986 (42 U.S.C. 11001-11050)

Endangered Species Act of 1973 (16 U.S.C. 1531-1544)

Energy Supply and Environmental Coordination Act of 1974 (15 U.S.C. 791-798)

Environmental Quality Improvement Act of 1970 (42 U.S.C. 4371-4375)

Federal Facility Compliance Act of 1992 (42 U.S.C. 6901 note)

Federal Insecticide, Fungicide and Rodenticide Act (7 U.S.C. 136-136y)

**SECTION FOURTEEN**  
**LIST OF STATUTES**

---

Federal Land Policy and Management Act of 1976 (43 U.S.C. 1701-1784)

Federal Water Pollution Control Act (33 U.S.C. 1251-1387)

Geothermal Energy Research, Development, and Demonstration Act of 1974 (30 U.S.C. 1101-1164)

Global Climate Protection Act of 1987 (15 U.S.C. 2901 note)

Hazardous Substance Response Revenue Act of 1980 (see 26 U.S.C. 4611, 4612, 4661, 4662)

Lead-Based Paint Exposure Reduction Act (15 U.S.C. 2681-2692)

Lead Contamination Control Act of 1988 (42 U.S.C. 300j-21 to 300j-25)

Low-Level Radioactive Waste Policy Act (42 U.S.C. 2021b-2021d)

Marine Protection, Research and Sanctuaries Act of 1972 (33 U.S.C. 1401-1445)

Mining and Mineral Resources Research Institute Act of 1984 (30 U.S.C. 1221-1230)

National Climate Program Act (15 U.S.C. 2901-2908)

National Contaminated Sediment Assessment and Management Act (33 U.S.C. 1271 note)

National Environmental Policy Act of 1969 (42 U.S.C. 4321-4370b)

National Ocean Pollution Planning Act of 1978 (33 U.S.C. 1701-1709)

Noise Control Act of 1972 (42 U.S.C. 4901-4918)

Nuclear Waste Policy Act of 1982 (42 U.S.C. 10101-10270)

Oil Pollution Act of 1990 (33 U.S.C. 2701-2761)

Organotin Anti-Fouling Paint Control Act of 1988 (33 U.S.C. 2401-2410)

Outer Continental Shelf Land Act Amendments of 1978 (43 U.S.C. 1801-1866)

Pollution Prevention Act of 1990 (42 U.S.C. 13101-13109)

Public Health Service Act (42 U.S.C. 300f-300j-11)

---

**SECTION FOURTEEN  
LIST OF STATUTES**

---

Renewable Resources Extension Act of 1978 (16 U.S.C. 1671-1676)

Resource Conservation and Recovery Act of 1976 (42 U.S.C. 6901-6991)

Safe Drinking Water Act (see Public Health Service Act Sections 1401-1451 (42 U.S.C. 300f-300j-26))

Soil and Water Resources Conservation Act of 1977 (16 U.S.C. 2001-2009)

Solid Waste Disposal Act (42 U.S.C. 6901-6991i)

Surface Mining Control and Reclamation Act of 1977 (30 U.S.C. 1201-1328)

Toxic Substances Control Act (15 U.S.C. 2601-2692)

Uranium Mill Tailings Radiation Control Act of 1978 (42 U.S.C. 7901-7942)

Water Resources Research Act of 1984 (42 U.S.C. 10301-10309)

Wood Residue Utilization Act of 1980 (16 U.S.C. 1681-1687)



**NO BID FORM**

---

---

To assist the County in obtaining good competition, we ask that each firm who has received Invitation to Bid #24-08-GR, **but does not wish to submit a bid**, state their reason(s) below and return this form to the County of Berks, Attn: Director of Contracts and Procurement, 633 Court Street, 13<sup>th</sup> Floor Services Center, Reading, PA 19601.

**Unfortunately, we must offer a “No Bid” at this time because:**

_____	1.	We do not wish to participate in the bid process.
_____	2.	We do not wish to bid under the terms and conditions of the Invitation to Bid document. Our objections are: _____ _____
_____	3.	We do not feel we can be competitive.
_____	4.	We cannot submit a Bid because of the marketing or franchising policies of our company.
_____	5.	We do not wish to sell to the County of Berks. Our objections are: _____ _____
_____	6.	We do not provide the items/services for which Bids are requested.
_____	7.	Other: _____ _____ _____

# APPENDIX A - CONSTRUCTION PLANS

NOTES:

1. WORK SHALL BE PERFORMED IN ACCORDANCE WITH THE 2018 INTERNATIONAL BUILDING CODE AND OTHER CODES AS ADOPTED BY THE TOWNSHIP OF BERN UNDER THE UNIFORM CONSTRUCTION CODE.
2. USE GROUP - U - UTILITY (STAIRS FROM ONE WALKING TRAIL TO ANOTHER)  
CONSTRUCTION TYPE - TYPE V-B



**EXISTING CONDITIONS PLAN**  
SCALE: 1"=10'

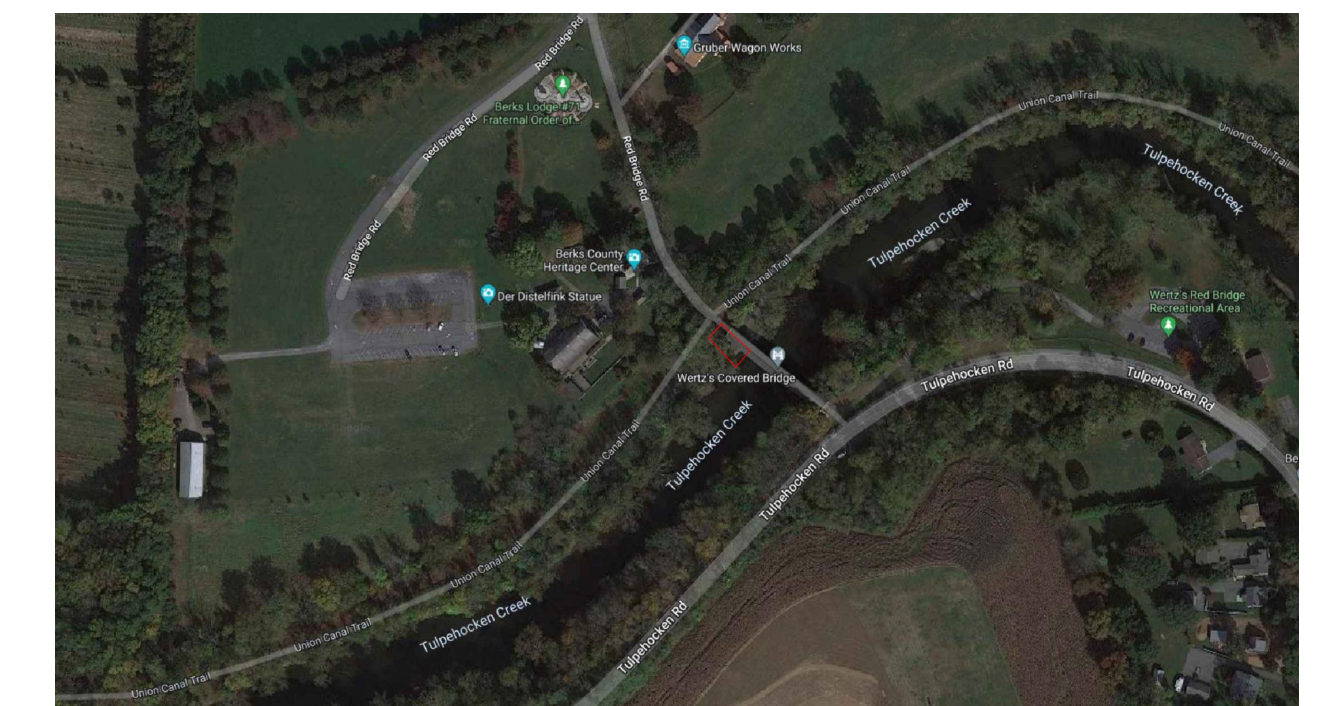

**LOCATION PLAN**  
SCALE: NO SCALE

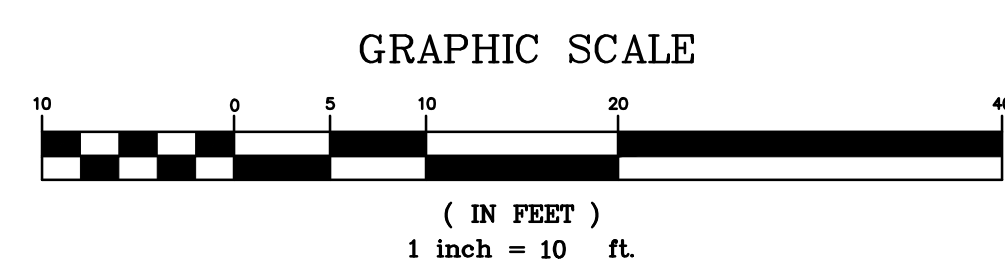

**LEGEND**

	EXISTING STREAM BANK
	EXISTING EDGE OF PAVEMENT
	EXISTING FENCE
	EXISTING 1' CONTOUR
	EXISTING 5' CONTOUR
	EXISTING TREE

COUNTY OF BERKS 633 COURT ST., 16TH FLOOR, READING, PA 19601 WERTZ'S COVERED BRIDGE STAIR REPLACEMENT 1102 RED BRIDGE ROAD, READING, PA 19605 EXISTING CONDITIONS PLAN / LOCATION PLAN		75 COMMERCE DRIVE WYOMISSING, PA 19610-1038 PHONE: 610-375-8822 FAX: 610-375-8977 www.greatvalleyconsultants.com	
		<b>GVC</b> GREAT VALLEY CONSULTANTS ENGINEERS • ARCHITECTS • PLANNERS • SURVEYORS • CONSULTANTS	
NO.	DATE	REVISIONS	
SURVEY NOTEBOOK:			
DRAFTED BY: LAJ/IRM		1"=10'	02/24/2023
CHECKED BY:		SCALE	DATE
APPROVALS:		3186-008-D-001	
		DRAWING NUMBER	

FILE NAME: P:\3000\3186 - County of Berks\Stairs Replacement Plans-02242023.dwg

# APPENDIX A - CONSTRUCTION PLANS

**NOTES:**

1. WORK SHALL BE PERFORMED IN ACCORDANCE WITH THE 2018 INTERNATIONAL BUILDING CODE AND OTHER CODES AS ADOPTED BY THE TOWNSHIP OF BERN UNDER THE UNIFORM CONSTRUCTION CODE.
2. USE GROUP - U - UTILITY (STAIRS FROM ONE WALKING TRAIL TO ANOTHER) CONSTRUCTION TYPE - TYPE V-B
3. ALL WOOD FRAMING ADJACENT TO MASONRY OR CONCRETE SHALL BE PRESSURE-TREATED LUMBER. ALL WOOD FRAMING FOR STAIRS, POSTS, JOISTS, RAILINGS, ETC SHALL BE PRESSURE-TREATED LUMBER. ALL POSTS SHALL BE TREATED / RATED FOR GROUND CONTACT.
4. ALL FASTENERS FOR HANGERS OR STRAPS TO BE GALVANIZED NAILS APPROVED FOR USE BY THE MANUFACTURER. ALL FASTENERS UTILIZED FOR STAIR FRAMING SHALL BE GALVANIZED AND RATED FOR CONTACT WITH PRESSURE TREATED LUMBER.
5. CONTRACTOR SHALL PROVIDE ALL EXCAVATION REQUIRED FOR THE INSTALLATION OF THE POSTS AND FOR ANY STAIR OR PLATFORM CONSTRUCTION.
6. CONTRACTOR SHALL PROVIDE ALL SURVEYING / LAYOUT OF THE PROPOSED STAIR. REVIEW LAYOUT OF STAIR WITH OWNER'S REPRESENTATIVES PRIOR TO INSTALLATION OF POSTS, PLATFORM AND STAIRS.
7. CONTRACTOR SHALL PROVIDE ANY ADDITIONAL SCREENINGS AND /OR REGRADING OF THE LANDING AT THE STAIR RUN TO PROVIDE A BOTTOM LANDING WITH A MAXIMUM SLOPE OF 1/4" PER FOOT.
8. THE TOP LANDING / PLATFORM SHALL BE FLUSH WITH THE EXISTING PAVING OF THE ROAD TO THE BRIDGE.

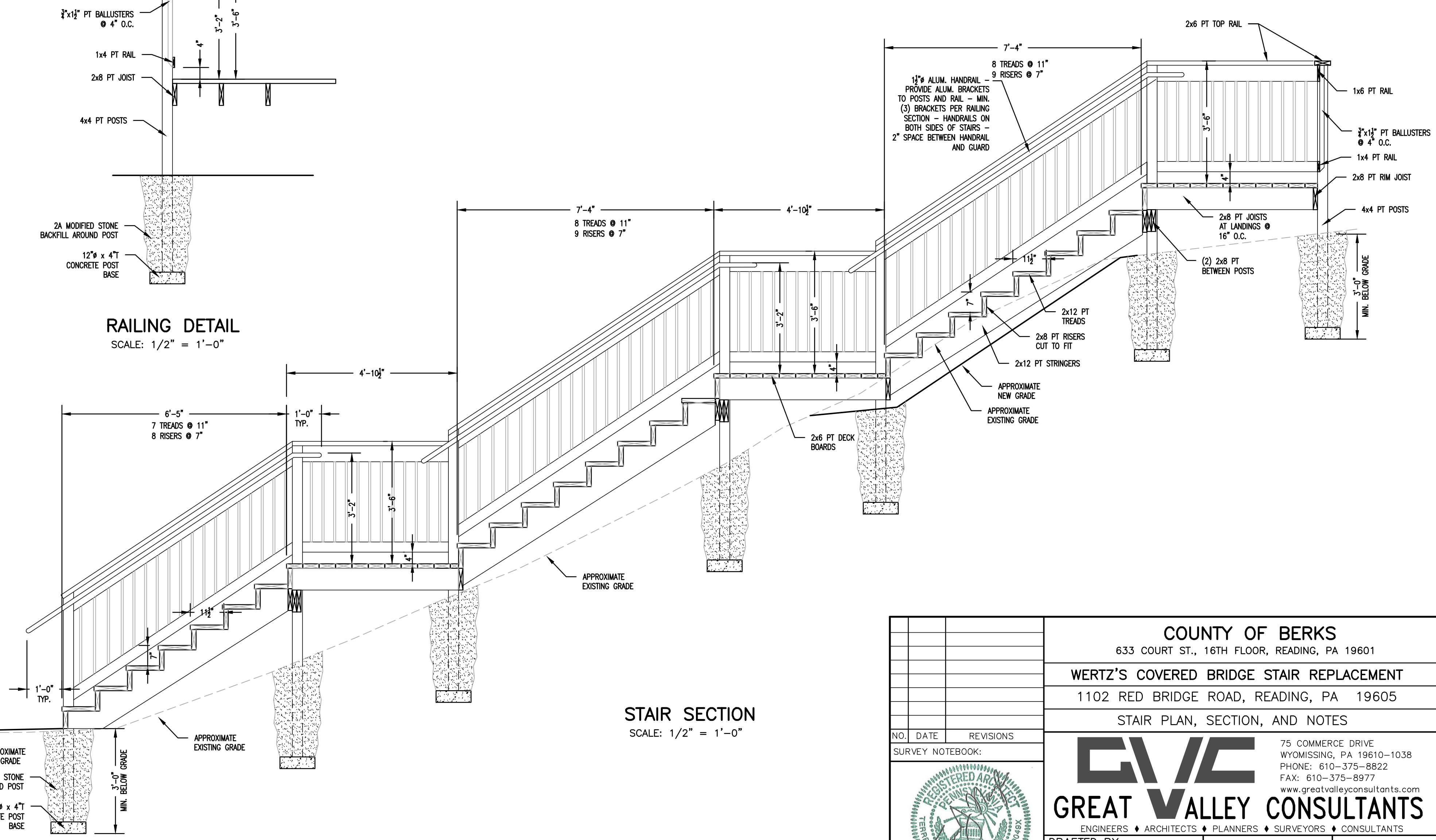
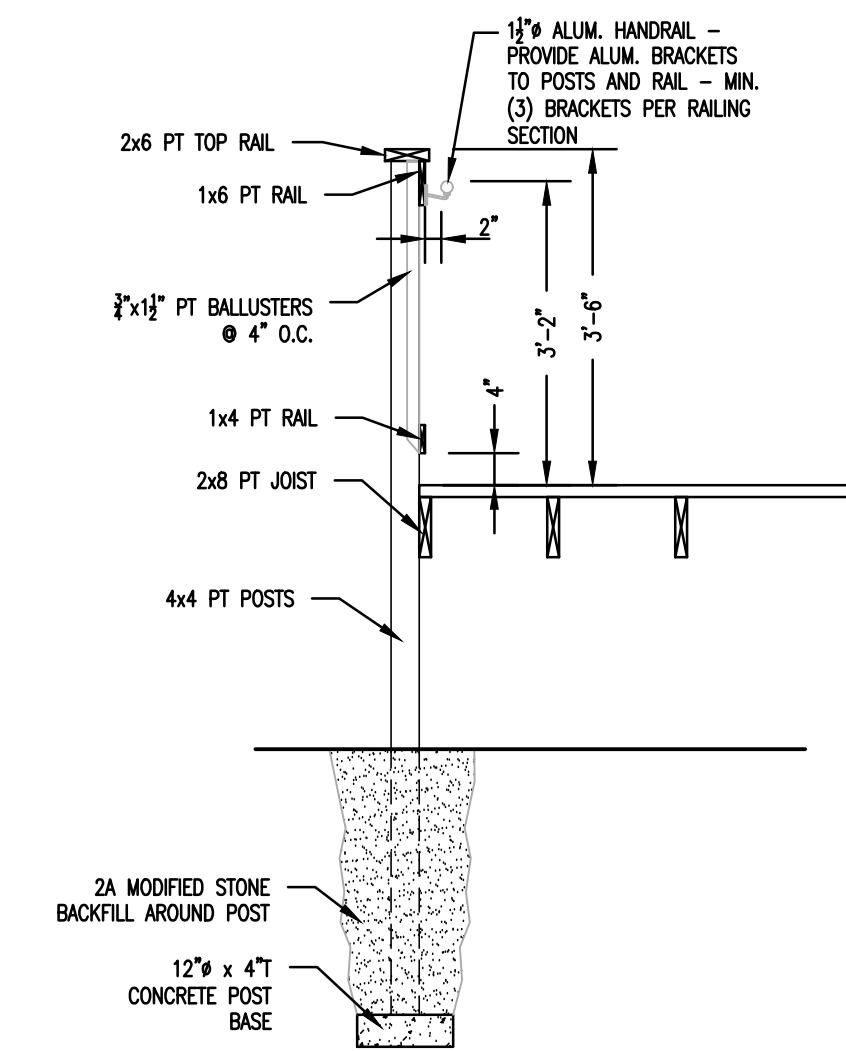
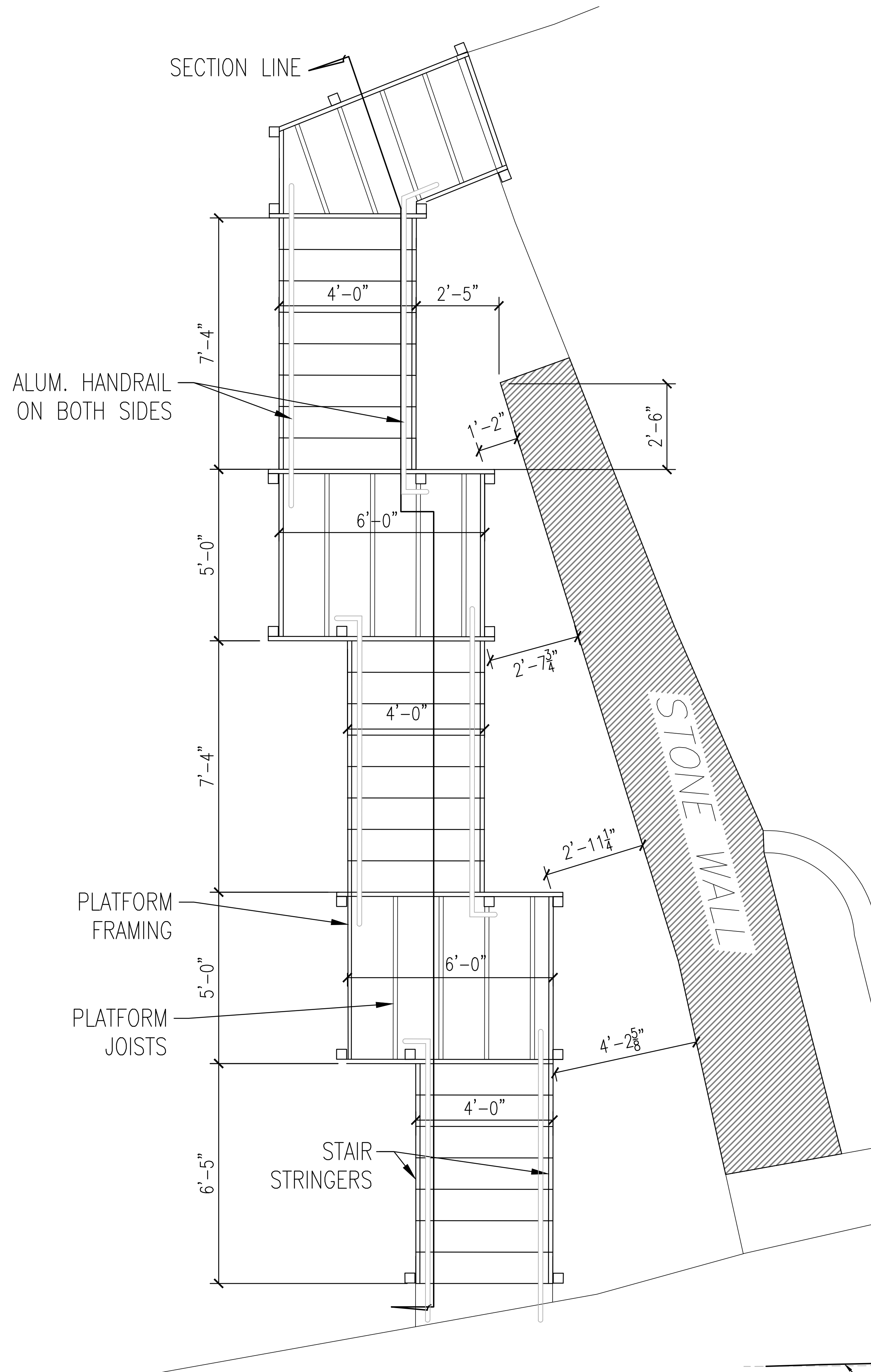
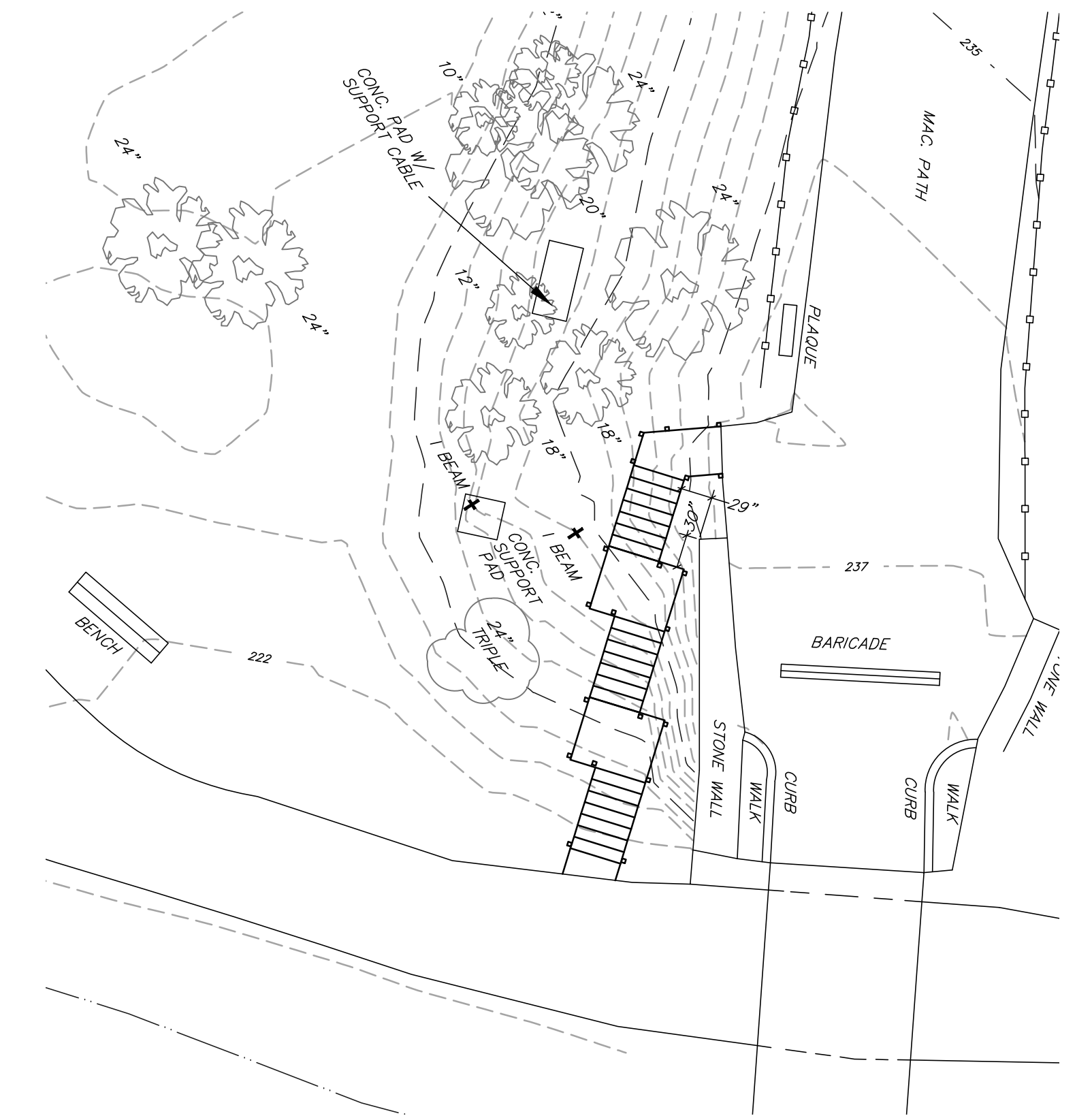

COUNTY OF BERKS 633 COURT ST., 16TH FLOOR, READING, PA 19601	
WERTZ'S COVERED BRIDGE STAIR REPLACEMENT 1102 RED BRIDGE ROAD, READING, PA 19605	
STAIR PLAN, SECTION, AND NOTES	
	
75 COMMERCE DRIVE WYOMISSING, PA 19610-1038 PHONE: 610-375-8822 FAX: 610-375-8977 www.greatvalleyconsultants.com	
ENGINEERS • ARCHITECTS • PLANNERS • SURVEYORS • CONSULTANTS	
DRAFTED BY: T.J.N.	AS NOTED 02/24/2023
CHECKED BY:	SCALE DATE
APPROVALS:	3186-008-D-002
	DRAWING NUMBER

# APPENDIX A - CONSTRUCTION PLANS

## PROJECT SCOPE

The Work of this project, entitled Wertz's Covered Bridge Stair Replacement for the County of Berks, consists of furnishing all labor, materials, equipment and all other necessary items required to complete the work as indicated in the Drawings and Specifications.

The Contractor shall carefully study and compare all contract documents with each other and with any other information provided by the Owner. The Contractor shall report all errors, inconsistencies or omissions to the Owner prior to the submission of the bid / proposal. The Contractor is responsible to provide all items of the Work normally required to complete the project as designed and as required by the applicable local codes, including the Township's adoption of the Uniform Construction Code of the Commonwealth of Pennsylvania.

The General Contractor is responsible for coordinating the work of all trades.

## INSTRUCTIONS TO BIDDERS

See the Project Manual for the Instructions to Bidders and Bid Forms.

## DIVISION 1 - GENERAL CONDITIONS

The form for the Agreement for the Work of this project shall be as included in the Project Manual.

### Contractor's Representative:

The Contractor shall appoint a project manager who will be responsible for overseeing the construction. All correspondence / directives between the Contractor and the Owner are to be through the designated Project Manager.

### Owner's Construction Representative:

The Owner shall designate a Construction Representative who will be responsible for overseeing the construction. All correspondence / directives between the Contractor and the Owner are to be through the designated Construction Representative. The Construction Representative will be responsible for reviewing and certifying the Contractor's Application for Payments and shall be responsible for documenting any changes to the Contract.

### Changes to the Contract:

All changes to the Contract shall be documented through a change order executed by both the Contractor and the Owner. Payment for any changes shall not be provided until the change is documented and both the Contractor and Owner have executed the change order.

### Building Code Compliance:

The renovations of the building are to be built in compliance with the all requirements of the Uniform Construction Code as adopted by the Township of Bern, Berks County, PA.

### Inspections:

The Contractor is responsible for scheduling the inspections required by the local building codes. The costs for any reinspections shall be the responsibility of the Contractor.

### Permits:

The Contractor is responsible for acquiring the zoning and building permits. All other permits are the responsibility of the Owner. Any contractor licenses or business privilege permits are the responsibility of the Contractor.

### Standards:

All references to standard trade specifications such as ASTM, Federal Specifications and other standards, publications and specifications shall be the issues of these documents in effect at the time of the Bid and shall be incorporated into these Contract Documents by these references.

### Substitutions:

See the Project Manual for the process of approvals for substitutions.

### Submittals:

The Contractor shall submit to shop drawings, product data, finish samples, and similar submittals as listed in the Project Manual for the aluminum handrails.

### Document Ownership:

All drawings, specifications and other documents prepared for this project, and all copies thereof, shall remain the property of the Engineer. Utilization of these documents for any other use other than the work of this project is strictly prohibited. All rights to these documents are reserved by the Engineer.

### Temporary Utilities:

The Owner's electric and water may be utilized by the contractor for the performance of the Work of this project, except that the Contractor is responsible to supply the source for any temporary electric for welding purposes. The misuse or waste of the Owner's utilities is not permitted, and the Contractor may be charged for any such misuse.

The Contractor shall be responsible for the provision, installation, and removal all temporary partitions, dropcloths, tarps, etc. required to protect the existing occupied areas from the areas of the project Work.

### Cutting and Patching:

Inspect all existing conditions prior to any cutting operations. Provide all required protection, including, but not limited to, shoring, bracing, and supports to maintain the structural integrity of the existing work to remain.

Patch and / or repair all areas or surfaces disturbed by the Work with new finishes or materials to match the adjacent existing materials or finish.

### Hidden Conditions:

The Contractor shall notify the Architect and Owner immediately of any hidden or latent conditions in the project area materially differing from the scope of the work indicated in the contract documents before they are disturbed. The Owner's representative will then promptly investigate the conditions, and if the existing conditions are found to be materially different from the scope of the work shown or noted in the construction documents a change will be processed in the construction documents. The Contractor will review these changes and provide a cost breakdown for any increase or decrease in the contract sum. A change order to incorporate the change in the construction documents will be processed.

### Weather Conditions:

The Contractor shall protect the Work of this project and shall protect the existing occupied portions of the building from damage from the weather resulting from work that the Contractor performed as part of this project. Any materials, equipment, furnishings, or other parts of the building which are damaged by weather as a result of the Contractor's, or their Subcontractor's, failure to protect the building or materials from the weather shall be replaced by the Contractor at the Contractor's expense.

### Final Cleaning:

The Contractor, upon completion of the Work, shall present the project to the Owner in a cleaned state and ready for occupancy. All surfaces shall be wiped clean, all carpeted areas shall be vacuumed, and all resilient flooring areas shall be swept and mopped clean. All glass surfaces shall be cleaned and all labels, tags, etc. shall be removed.

## DIVISION 2 - SITEWORK

### Demolition:

The Contractor shall comply with all requirements of these specifications and with all applicable requirements of the local, state and federal regulations.

The Contractor shall remove and properly dispose of all materials of existing stairs except as otherwise noted for items or materials to be salvaged and/or reused. Areas for dumpsters to be located and areas for storage of the salvaged materials shall be coordinated with the Owner. The Contractor shall provide protection of the salvaged materials during the storage period.

### Excavation:

The Contractor shall be responsible for all excavation required for the installation of the new stairs. All excavation is unclassified - should bedrock be encountered the Contractor shall contact the Owner and the Building Code Official to determine if the depth of the post footing excavation where it hit the bedrock is sufficient for protection from frost heaving. The Building Code Official shall have the final determination on the depth of the excavation if bedrock is encountered.

### Crushed Stone Backfill at Posts:

Provide 2A Modified crushed stone backfill at all stair posts. Compact stone in lifts of 8" maximum thickness.

## DIVISION 3 - CONCRETE

### General:

Unless noted otherwise, all concrete shall be a minimum of 3,500 psi concrete after the 28 day break. Contractor shall provide concrete tests for the concrete placed at the site. Provide test results from the 28 day break tests. Bottom of poured concrete footing to be no less than 36" below grade unless approve by Building Code Official.

At Contractor option prefabricated concrete discs for post footings may be used in lieu of poured concrete; Discs to be minimum 4" thick with minimum compressive strength of 4000 psi. Footing discs shall be placed on a base of 2A Modified crushed stone - minimum thickness of 4". Bottom of disc to be no less than 36" below grade unless approved by Building Code Official.

## DIVISION 4 - MASONRY

Not applicable.

## DIVISION 5 - METALS

### Aluminum Handrail:

Contractor shall provide new aluminum handrails as indicated on the plans and sections. Aluminum tube to comply with ASTM B221/B221M, Alloy 6063-T5/T52. Handrails, caps, brackets and other components are to be mill finish.

Brackets to be equal to #376 from Julius Blum. Provide paint or plastic barrier to protect back of bracket from pressure-treated wood.

Provide stainless steel anchors as required for fastening of brackets to wood rail. Provide thru-bolts with stainless steel washers.

## DIVISION 6 - WOOD / PLASTIC

### Rough Framing:

All wood framing shall be structural grade lumber. Provide all wood blocking and fire blocking as required. All wood in contact with masonry or concrete shall be pressure-treated lumber. All pressure-treated wood in contact with the ground or buried below grade shall be AWPA UC4B or UC4C.

### Finish Carpentry:

Provide miscellaneous wood trim and other finish carpentry items as noted on the drawings or as required for closure of openings. All wood trim noted on the Drawings shall be pressure-treated lumber unless specifically noted otherwise.

## DIVISION 7 - THERMAL & MOISTURE PROTECTION

Not Applicable.

## DIVISION 8 - DOORS AND WINDOWS

Not Applicable.

## DIVISION 9 - FINISHES

Not Applicable.

## DIVISION 10 - SPECIALTIES

Not Applicable.

## DIVISION 11 - EQUIPMENT

Not Applicable.

## DIVISION 12 - FURNISHINGS

Not Applicable.

## DIVISION 13 - SPECIAL CONSTRUCTION

Not Applicable.

## DIVISION 14 - CONVEYING SYSTEMS



Not Applicable.

## DIVISION 15 - MECHANICAL

Not Applicable.

## DIVISION 16 - ELECTRICAL

Not Applicable.

		<b>COUNTY OF BERKS</b> 633 COURT ST., 16TH FLOOR, READING, PA 19601			
		<b>WERTZ'S COVERED BRIDGE STAIR REPLACEMENT</b> 1102 RED BRIDGE ROAD, READING, PA 19605			
		PROJECT SPECIFICATIONS			
NO.	DATE	REVISIONS			
SURVEY NOTEBOOK:					
		 <b>GREAT VALLEY CONSULTANTS</b> <small>ENGINEERS ♦ ARCHITECTS ♦ PLANNERS ♦ SURVEYORS ♦ CONSULTANTS</small>			
		75 COMMERCE DRIVE WYOMISSING, PA 19610-1038 PHONE: 610-375-8822 FAX: 610-375-8977 www.greatvalleyconsultants.com			
		DRAFTED BY:	TJN	AS NOTED	02/24/2023
		CHECKED BY:		SCALE	DATE
APPROVALS:		<b>3186-008-D-003</b>			
		DRAWING NUMBER			

# APPENDIX B - PREVAILING WAGE RATES

## BUREAU OF LABOR LAW COMPLIANCE PREVAILING WAGES PROJECT RATES

Project Name:	Wertz Covered Bridge Stair Replacement Project
Awarding Agency:	County of Berks
Contract Award Date:	5/16/2024
Serial Number:	24-02646
Project Classification:	Highway
Determination Date:	3/15/2024
Assigned Field Office:	Scranton
Field Office Phone Number:	(570)963-4577
Toll Free Phone Number:	(877)214-3962
Project County:	Berks County

**APPENDIX B - PREVAILING WAGE RATES**

**BUREAU OF LABOR LAW COMPLIANCE  
PREVAILING WAGES PROJECT RATES**

<b>Project: 24-02646 - Building</b>	<b>Effective Date</b>	<b>Expiration Date</b>	<b>Hourly Rate</b>	<b>Fringe Benefits</b>	<b>Total</b>
Asbestos & Insulation Workers	6/26/2023		\$38.70	\$29.11	\$67.81
Asbestos & Insulation Workers	7/1/2024		\$35.80	\$34.06	\$69.86
Boilermakers	1/1/2023		\$51.27	\$35.30	\$86.57
Boilermakers	1/1/2024		\$52.10	\$35.72	\$87.82
Bricklayers, Stone Masons, Pointers, Caulkers, Cleaners	4/30/2023		\$39.98	\$17.17	\$57.15
Bricklayers, Stone Masons, Pointers, Caulkers, Cleaners	4/28/2024		\$41.83	\$17.17	\$59.00
Bricklayers, Stone Masons, Pointers, Caulkers, Cleaners	5/4/2025		\$43.68	\$17.17	\$60.85
Carpenters, Drywall Hangers, Framers, Instrument Men, Lathers, Soft Floor Layers	6/1/2022		\$33.56	\$17.72	\$51.28
Carpenters, Drywall Hangers, Framers, Instrument Men, Lathers, Soft Floor Layers	6/1/2023		\$35.06	\$17.72	\$52.78
Carpenters, Drywall Hangers, Framers, Instrument Men, Lathers, Soft Floor Layers	6/1/2024		\$36.56	\$17.72	\$54.28
Cement Finishers & Plasterers	4/30/2023		\$28.23	\$22.27	\$50.50
Cement Finishers & Plasterers	4/28/2024		\$30.23	\$22.27	\$52.50
Cement Finishers & Plasterers	5/4/2025		\$32.23	\$22.27	\$54.50
Cement Finishers & Plasterers	5/3/2026		\$34.23	\$22.27	\$56.50
Cement Masons	5/1/2023		\$34.15	\$20.60	\$54.75
Dockbuilder, Pile Drivers	5/1/2023		\$50.48	\$37.99	\$88.47
Dockbuilder, Pile Drivers	5/1/2024		\$52.98	\$37.99	\$90.97
Dockbuilder, Pile Drivers	5/1/2025		\$55.23	\$37.99	\$93.22
Dockbuilder, Pile Drivers	5/1/2026		\$56.98	\$37.99	\$94.97
Dockbuilder/Pile Driver Diver	5/1/2023		\$58.41	\$41.74	\$100.15
Dockbuilder/Pile Driver Diver	5/1/2024		\$61.54	\$41.74	\$103.28
Dockbuilder/Pile Driver Diver	5/1/2025		\$64.35	\$41.74	\$106.09
Dockbuilder/Pile Driver Diver	5/1/2026		\$66.54	\$41.74	\$108.28
Dockbuilder/pile driver tender	5/1/2023		\$50.48	\$37.99	\$88.47
Dockbuilder/pile driver tender	5/1/2024		\$52.98	\$37.99	\$90.97
Dockbuilder/pile driver tender	5/1/2025		\$55.23	\$37.99	\$93.22
Dockbuilder/pile driver tender	5/1/2026		\$56.98	\$37.99	\$94.97
Drywall Finisher	5/1/2023		\$30.10	\$22.14	\$52.24
Electricians	9/1/2022		\$40.52	\$25.63	\$66.15
Electricians	9/1/2023		\$42.02	\$25.69	\$67.71
Elevator Constructor	1/1/2023		\$56.46	\$38.36	\$94.82
Elevator Constructor	1/1/2024		\$58.88	\$43.90	\$102.78
Floor Coverer	5/1/2023		\$36.21	\$18.36	\$54.57
Floor Coverer	5/1/2024		\$37.64	\$18.36	\$56.00
Glazier	5/1/2023		\$37.71	\$23.68	\$61.39
Iron Workers (Bridge, Structural Steel, Ornamental, Precast, Reinforcing)	7/1/2021		\$34.01	\$31.13	\$65.14
Iron Workers (Bridge, Structural Steel, Ornamental, Precast, Reinforcing)	7/1/2023		\$36.26	\$31.38	\$67.64
Laborers (Class 01 - See notes)	5/1/2023		\$27.62	\$16.77	\$44.39
Laborers (Class 01 - See notes)	5/1/2024		\$28.17	\$17.29	\$45.46

**APPENDIX B - PREVAILING WAGE RATES**

**BUREAU OF LABOR LAW COMPLIANCE  
PREVAILING WAGES PROJECT RATES**

<b>Project: 24-02646 - Building</b>	<b>Effective Date</b>	<b>Expiration Date</b>	<b>Hourly Rate</b>	<b>Fringe Benefits</b>	<b>Total</b>
Laborers (Class 02 - see notes)	5/1/2023		\$29.62	\$16.77	\$46.39
Laborers (Class 02 - see notes)	5/1/2024		\$30.17	\$17.29	\$47.46
Laborers (Class 03 - See notes)	5/1/2023		\$30.32	\$17.03	\$47.35
Laborers (Class 03 - See notes)	5/6/2024		\$30.82	\$17.83	\$48.65
Laborers (Class 04 - See notes)	5/1/2023		\$31.82	\$16.78	\$48.60
Laborers (Class 04 - See notes)	5/6/2024		\$32.32	\$17.83	\$50.15
Laborers (Class 05 - See notes)	5/1/2023		\$29.62	\$16.77	\$46.39
Laborers (Class 05 - See notes)	5/1/2024		\$30.17	\$17.29	\$47.46
Laborers (Class 06 - See notes)	5/1/2022		\$28.87	\$16.28	\$45.15
Laborers (Class 06 - See notes)	5/1/2024		\$29.52	\$17.29	\$46.81
Marble Mason	5/1/2023		\$35.81	\$16.73	\$52.54
Marble Mason	5/1/2024		\$37.76	\$16.73	\$54.49
Marble Mason	5/1/2025		\$39.71	\$16.73	\$56.44
Millwright	5/1/2019		\$39.14	\$20.08	\$59.22
Millwright	6/1/2023		\$39.21	\$22.95	\$62.16
Millwright	6/1/2024		\$41.07	\$22.95	\$64.02
Millwright	6/1/2025		\$43.00	\$22.95	\$65.95
Millwright	6/1/2026		\$44.97	\$22.95	\$67.92
Operators (Building, Class 01 - See Notes)	5/1/2023		\$42.57	\$29.24	\$71.81
Operators (Building, Class 01A - See Notes)	5/1/2023		\$44.82	\$29.90	\$74.72
Operators (Building, Class 02 - See Notes)	5/1/2023		\$42.29	\$29.15	\$71.44
Operators (Building, Class 02A - See Notes)	5/1/2023		\$44.54	\$29.82	\$74.36
Operators (Building, Class 03 - See Notes)	5/1/2023		\$39.57	\$28.34	\$67.91
Operators (Building, Class 04 - See Notes)	5/1/2023		\$38.42	\$28.02	\$66.44
Operators (Building, Class 05 - See Notes)	5/1/2023		\$37.97	\$27.89	\$65.86
Operators (Building, Class 06 - See Notes)	5/1/2023		\$37.10	\$27.62	\$64.72
Operators (Building, Class 07A- See Notes)	5/1/2023		\$51.63	\$33.34	\$84.97
Operators (Building, Class 07B- See Notes)	5/1/2023		\$51.28	\$33.24	\$84.52
Painters Class 1 (see notes)	5/1/2023		\$31.09	\$23.19	\$54.28
Painters Class 2 (see notes)	5/1/2023		\$30.09	\$23.19	\$53.28
Painters Class 3 (see notes)	5/1/2017		\$36.25	\$18.17	\$54.42
Piledrivers	5/1/2021		\$43.73	\$37.99	\$81.72
Plasterers	5/1/2023		\$31.33	\$20.83	\$52.16
plumber	5/1/2023		\$52.48	\$34.56	\$87.04
Roofers (Composition)	5/1/2023		\$42.63	\$34.62	\$77.25
Roofers (Shingle)	5/1/2023		\$32.85	\$22.10	\$54.95
Roofers (Slate & Tile)	5/1/2023		\$35.85	\$22.10	\$57.95
Sheet Metal Workers	6/1/2022		\$40.22	\$41.01	\$81.23
Sheet Metal Workers	6/1/2023		\$41.41	\$42.32	\$83.73
Sign Makers and Hangars	7/15/2022		\$30.54	\$24.35	\$54.89
Sign Makers and Hangars	7/15/2023		\$31.76	\$24.63	\$56.39
Sprinklerfitters	4/1/2023		\$44.33	\$28.04	\$72.37
Steamfitters	5/1/2023		\$57.07	\$41.99	\$99.06
Terrazzo Finisher	5/1/2023		\$35.79	\$19.25	\$55.04

**APPENDIX B - PREVAILING WAGE RATES**

**BUREAU OF LABOR LAW COMPLIANCE  
PREVAILING WAGES PROJECT RATES**

<b>Project: 24-02646 - Building</b>	<b>Effective Date</b>	<b>Expiration Date</b>	<b>Hourly Rate</b>	<b>Fringe Benefits</b>	<b>Total</b>
Terrazzo Finisher	5/1/2024		\$37.16	\$19.26	\$56.42
Terrazzo Grinder	5/1/2023		\$36.54	\$19.25	\$55.79
Terrazzo Grinder	5/1/2024		\$37.92	\$19.26	\$57.18
Terrazzo Mechanics	5/1/2023		\$36.51	\$21.00	\$57.51
Terrazzo Mechanics	5/1/2024		\$37.94	\$21.01	\$58.95
Tile & Marble Finisher	5/1/2023		\$32.16	\$16.24	\$48.40
Tile & Marble Finisher	5/1/2024		\$34.11	\$16.24	\$50.35
Tile & Marble Finisher	5/1/2025		\$36.06	\$16.24	\$52.30
Tile & Marble Finisher	5/1/2026		\$38.01	\$16.24	\$54.25
Tile Setter	5/1/2023		\$35.81	\$16.73	\$52.54
Tile Setter	5/1/2024		\$37.76	\$16.73	\$54.49
Tile Setter	5/1/2025		\$39.71	\$16.73	\$56.44
Truckdriver class 1(see notes)	5/1/2021		\$37.72	\$0.00	\$37.72
Truckdriver class 2 (see notes)	5/1/2021		\$37.79	\$0.00	\$37.79
Truckdriver class 3 (see notes)	5/1/2021		\$38.28	\$0.00	\$38.28
Window Film / Tint Installer	6/1/2019		\$24.52	\$12.08	\$36.60



**APPENDIX B - PREVAILING WAGE RATES**

**BUREAU OF LABOR LAW COMPLIANCE  
PREVAILING WAGES PROJECT RATES**

<b>Project: 24-02646 - Heavy/Highway</b>	<b>Effective Date</b>	<b>Expiration Date</b>	<b>Hourly Rate</b>	<b>Fringe Benefits</b>	<b>Total</b>
Carpenter - Chief of Party (Surveying & Layout)	5/1/2021		\$41.42	\$15.49	\$56.91
Carpenter - Instrument Person (Surveying & Layout)	5/1/2021		\$36.02	\$15.49	\$51.51
Carpenter - Rodman I (Survey & Layout)	5/1/2021		\$28.82	\$12.39	\$41.21
Carpenter	5/1/2023		\$35.32	\$19.09	\$54.41
Carpenter	5/1/2024		\$36.12	\$19.79	\$55.91
Carpenter	5/1/2025		\$36.87	\$20.49	\$57.36
Carpenter	5/1/2026		\$37.63	\$21.18	\$58.81
Carpenter Welder	5/1/2023		\$36.07	\$19.09	\$55.16
Carpenter Welder	5/1/2024		\$36.87	\$19.79	\$56.66
Carpenter Welder	5/1/2025		\$37.62	\$20.49	\$58.11
Carpenter Welder	5/1/2026		\$38.38	\$21.18	\$59.56
Carpenters - Piledriver/Welder	1/1/2023		\$36.07	\$19.09	\$55.16
Carpenters - Piledriver/Welder	1/1/2024		\$36.87	\$19.79	\$56.66
Carpenters - Piledriver/Welder	1/1/2025		\$37.62	\$20.49	\$58.11
Carpenters - Piledriver/Welder	1/1/2026		\$38.38	\$21.18	\$59.56
Cement Finishers	1/1/2017		\$27.70	\$20.20	\$47.90
Dockbuilder, Pile Drivers	5/1/2023		\$50.48	\$37.99	\$88.47
Dockbuilder, Pile Drivers	5/1/2024		\$52.98	\$37.99	\$90.97
Dockbuilder, Pile Drivers	5/1/2025		\$55.23	\$37.99	\$93.22
Dockbuilder, Pile Drivers	5/1/2026		\$56.98	\$37.99	\$94.97
Dockbuilder/Pile Driver Diver	5/1/2023		\$58.41	\$41.74	\$100.15
Dockbuilder/Pile Driver Diver	5/1/2024		\$61.54	\$41.74	\$103.28
Dockbuilder/Pile Driver Diver	5/1/2025		\$64.35	\$41.74	\$106.09
Dockbuilder/Pile Driver Diver	5/1/2026		\$66.54	\$41.74	\$108.28
Dockbuilder/pile driver tender	5/1/2023		\$50.48	\$37.99	\$88.47
Dockbuilder/pile driver tender	5/1/2024		\$52.98	\$37.99	\$90.97
Dockbuilder/pile driver tender	5/1/2025		\$55.23	\$37.99	\$93.22
Dockbuilder/pile driver tender	5/1/2026		\$56.98	\$37.99	\$94.97
Electric Lineman	5/30/2022		\$50.28	\$28.47	\$78.75
Electric Lineman	5/29/2023		\$51.40	\$29.62	\$81.02
Electric Lineman	6/3/2024		\$52.80	\$30.61	\$83.41
Iron Workers (Bridge, Structural Steel, Ornamental, Precast, Reinforcing)	7/1/2021		\$34.01	\$31.13	\$65.14
Iron Workers (Bridge, Structural Steel, Ornamental, Precast, Reinforcing)	7/1/2023		\$36.26	\$31.38	\$67.64
Laborers (Class 01 - See notes)	5/1/2023		\$24.81	\$18.99	\$43.80
Laborers (Class 01 - See notes)	5/1/2024		\$25.61	\$19.49	\$45.10
Laborers (Class 02 - See notes)	5/1/2023		\$31.43	\$18.99	\$50.42
Laborers (Class 02 - See notes)	5/1/2024		\$32.23	\$19.49	\$51.72
Laborers (Class 03 - See notes)	5/1/2023		\$28.42	\$18.99	\$47.41
Laborers (Class 03 - See notes)	5/1/2024		\$29.22	\$19.49	\$48.71
Laborers (Class 04 - See notes)	5/1/2023		\$28.77	\$18.99	\$47.76
Laborers (Class 04 - See notes)	5/1/2024		\$29.57	\$19.49	\$49.06
Laborers (Class 05 - See notes)	5/1/2023		\$29.44	\$18.99	\$48.43
Laborers (Class 05 - See notes)	5/1/2024		\$30.24	\$19.49	\$49.73

**APPENDIX B - PREVAILING WAGE RATES**

**BUREAU OF LABOR LAW COMPLIANCE  
PREVAILING WAGES PROJECT RATES**

<b>Project: 24-02646 - Heavy/Highway</b>	<b>Effective Date</b>	<b>Expiration Date</b>	<b>Hourly Rate</b>	<b>Fringe Benefits</b>	<b>Total</b>
Laborers (Class 06 - See notes)	5/1/2023		\$28.86	\$18.99	\$47.85
Laborers (Class 06 - See notes)	5/1/2024		\$29.66	\$19.49	\$49.15
Laborers (Class 07 - See notes)	5/1/2023		\$29.15	\$18.99	\$48.14
Laborers (Class 07 - See notes)	5/1/2024		\$29.95	\$19.49	\$49.44
Laborers (Class 08 - See notes)	5/1/2023		\$29.63	\$18.99	\$48.62
Laborers (Class 08 - See notes)	5/1/2024		\$30.43	\$19.49	\$49.92
Millwright	6/1/2023		\$41.51	\$23.33	\$64.84
Millwright	6/1/2024		\$43.46	\$23.33	\$66.79
Millwright	6/1/2025		\$45.46	\$23.33	\$68.79
Millwright	6/1/2026		\$47.52	\$23.33	\$70.85
Operators (Heavy, Class 01 - See Notes)	5/1/2023		\$41.14	\$28.82	\$69.96
Operators (Heavy, Class 01 - See Notes)	5/1/2024		\$42.30	\$29.66	\$71.96
Operators (Heavy, Class 01 - See Notes)	5/1/2025		\$43.46	\$30.50	\$73.96
Operators (Heavy, Class 01 - See Notes)	5/1/2026		\$44.61	\$31.35	\$75.96
Operators (Heavy, Class 01A - See Notes)	5/1/2023		\$43.39	\$29.48	\$72.87
Operators (Heavy, Class 01A - See Notes)	5/1/2024		\$44.55	\$30.32	\$74.87
Operators (Heavy, Class 01A - See Notes)	5/1/2025		\$45.71	\$31.16	\$76.87
Operators (Heavy, Class 01A - See Notes)	5/1/2026		\$46.86	\$32.01	\$78.87
Operators (Heavy, Class 02 - See Notes)	5/1/2023		\$40.86	\$28.73	\$69.59
Operators (Heavy, Class 02 - See Notes)	5/1/2024		\$42.02	\$29.57	\$71.59
Operators (Heavy, Class 02 - See Notes)	5/1/2025		\$43.18	\$30.41	\$73.59
Operators (Heavy, Class 02 - See Notes)	5/1/2026		\$44.34	\$31.25	\$75.59
Operators (Heavy, Class 02A - See Notes)	5/1/2023		\$43.11	\$29.40	\$72.51
Operators (Heavy, Class 02A - See Notes)	5/1/2024		\$44.27	\$30.24	\$74.51
Operators (Heavy, Class 02A - See Notes)	5/1/2025		\$45.43	\$31.08	\$76.51
Operators (Heavy, Class 02A - See Notes)	5/1/2026		\$46.59	\$31.92	\$78.51
Operators (Heavy, Class 03 - See Notes)	5/1/2023		\$37.95	\$27.86	\$65.81
Operators (Heavy, Class 03 - See Notes)	5/1/2024		\$39.11	\$28.70	\$67.81
Operators (Heavy, Class 03 - See Notes)	5/1/2025		\$40.26	\$29.55	\$69.81
Operators (Heavy, Class 03 - See Notes)	5/1/2026		\$41.43	\$30.38	\$71.81
Operators (Heavy, Class 04 - See Notes)	5/1/2023		\$36.80	\$27.54	\$64.34
Operators (Heavy, Class 04 - See Notes)	5/1/2024		\$37.96	\$28.38	\$66.34
Operators (Heavy, Class 04 - See Notes)	5/1/2025		\$39.12	\$29.22	\$68.34
Operators (Heavy, Class 04 - See Notes)	5/1/2026		\$40.28	\$30.06	\$70.34
Operators (Heavy, Class 05 - See Notes)	5/1/2023		\$36.35	\$27.41	\$63.76
Operators (Heavy, Class 05 - See Notes)	5/1/2024		\$37.51	\$28.25	\$65.76
Operators (Heavy, Class 05 - See Notes)	5/1/2025		\$38.67	\$29.09	\$67.76
Operators (Heavy, Class 05 - See Notes)	5/1/2026		\$39.83	\$29.93	\$69.76
Operators (Heavy, Class 06 - See Notes)	5/1/2023		\$35.48	\$27.14	\$62.62
Operators (Heavy, Class 06 - See Notes)	5/1/2024		\$36.64	\$27.98	\$64.62
Operators (Heavy, Class 06 - See Notes)	5/1/2025		\$37.80	\$28.82	\$66.62
Operators (Heavy, Class 06 - See Notes)	5/1/2026		\$38.96	\$29.66	\$68.62
Operators (Heavy, Class 07A - See Notes)	5/1/2023		\$49.93	\$32.83	\$82.76
Operators (Heavy, Class 07A - See Notes)	5/1/2024		\$51.39	\$33.77	\$85.16

**APPENDIX B - PREVAILING WAGE RATES**

**BUREAU OF LABOR LAW COMPLIANCE  
PREVAILING WAGES PROJECT RATES**

<b>Project: 24-02646 - Heavy/Highway</b>	<b>Effective Date</b>	<b>Expiration Date</b>	<b>Hourly Rate</b>	<b>Fringe Benefits</b>	<b>Total</b>
Operators (Heavy, Class 07A - See Notes)	5/1/2025		\$52.85	\$34.71	\$87.56
Operators (Heavy, Class 07A - See Notes)	5/1/2026		\$54.32	\$35.64	\$89.96
Operators (Heavy, Class 07B - See Notes)	5/1/2023		\$49.58	\$32.73	\$82.31
Operators (Heavy, Class 07B - See Notes)	5/1/2024		\$51.04	\$33.67	\$84.71
Operators (Heavy, Class 07B - See Notes)	5/1/2025		\$52.51	\$34.60	\$87.11
Operators (Heavy, Class 07B - See Notes)	5/1/2026		\$53.97	\$35.54	\$89.51
Operators (Highway, Class 01 - See Notes)	5/1/2023		\$40.25	\$28.55	\$68.80
Operators (Highway, Class 01 - See Notes)	5/1/2024		\$41.41	\$29.39	\$70.80
Operators (Highway, Class 01 - See Notes)	5/1/2025		\$42.56	\$30.24	\$72.80
Operators (Highway, Class 01 - See Notes)	5/1/2026		\$43.72	\$31.08	\$74.80
Operators (Highway, Class 01a - See Notes)	5/1/2023		\$42.50	\$29.23	\$71.73
Operators (Highway, Class 01a - See Notes)	5/1/2024		\$43.66	\$30.07	\$73.73
Operators (Highway, Class 01a - See Notes)	5/1/2025		\$44.81	\$30.92	\$75.73
Operators (Highway, Class 01a - See Notes)	5/1/2026		\$45.97	\$31.76	\$77.73
Operators (Highway, Class 02 - See Notes)	5/1/2023		\$39.08	\$28.20	\$67.28
Operators (Highway, Class 02 - See Notes)	5/1/2024		\$40.24	\$29.04	\$69.28
Operators (Highway, Class 02 - See Notes)	5/1/2025		\$41.39	\$29.89	\$71.28
Operators (Highway, Class 02 - See Notes)	5/1/2026		\$42.55	\$30.73	\$73.28
Operators (Highway, Class 03 - See Notes)	5/1/2023		\$38.39	\$27.99	\$66.38
Operators (Highway, Class 03 - See Notes)	5/1/2024		\$39.55	\$28.83	\$68.38
Operators (Highway, Class 03 - See Notes)	5/1/2025		\$40.70	\$29.68	\$70.38
Operators (Highway, Class 03 - See Notes)	5/1/2026		\$41.87	\$30.51	\$72.38
Operators (Highway, Class 04 - See Notes)	5/1/2023		\$37.94	\$27.86	\$65.80
Operators (Highway, Class 04 - See Notes)	5/1/2024		\$39.10	\$28.70	\$67.80
Operators (Highway, Class 04 - See Notes)	5/1/2025		\$40.26	\$29.54	\$69.80
Operators (Highway, Class 04 - See Notes)	5/1/2026		\$41.41	\$30.39	\$71.80
Operators (Highway, Class 05 - See Notes)	5/1/2023		\$37.42	\$27.72	\$65.14
Operators (Highway, Class 05 - See Notes)	5/1/2024		\$38.58	\$28.56	\$67.14
Operators (Highway, Class 05 - See Notes)	5/1/2025		\$39.73	\$29.41	\$69.14
Operators (Highway, Class 05 - See Notes)	5/1/2026		\$40.89	\$30.25	\$71.14
Operators (Highway, Class 06 - See Notes)	5/1/2023		\$40.48	\$28.62	\$69.10
Operators (Highway, Class 06 - See Notes)	5/1/2024		\$41.64	\$29.46	\$71.10
Operators (Highway, Class 06 - See Notes)	5/1/2025		\$42.80	\$30.30	\$73.10
Operators (Highway, Class 06 - See Notes)	5/1/2026		\$43.95	\$31.15	\$75.10
Operators (Highway, Class 06/A - See Notes)	5/1/2023		\$42.73	\$29.28	\$72.01
Operators (Highway, Class 06/A - See Notes)	5/1/2024		\$43.89	\$30.12	\$74.01
Operators (Highway, Class 06/A - See Notes)	5/1/2025		\$45.05	\$30.96	\$76.01
Operators (Highway, Class 06/A - See Notes)	5/1/2026		\$46.21	\$31.80	\$78.01
Operators (Highway, Class 07/A - See Notes)	5/1/2023		\$48.86	\$32.51	\$81.37
Operators (Highway, Class 07/A - See Notes)	5/1/2024		\$50.32	\$33.45	\$83.77
Operators (Highway, Class 07/A - See Notes)	5/1/2025		\$51.79	\$34.38	\$86.17
Operators (Highway, Class 07/A - See Notes)	5/1/2026		\$53.25	\$35.32	\$88.57
Operators (Highway, Class 07/B - See Notes)	5/1/2023		\$47.44	\$32.10	\$79.54
Operators (Highway, Class 07/B - See Notes)	5/1/2024		\$48.91	\$33.03	\$81.94

**APPENDIX B - PREVAILING WAGE RATES**

**BUREAU OF LABOR LAW COMPLIANCE  
PREVAILING WAGES PROJECT RATES**

<b>Project: 24-02646 - Heavy/Highway</b>	<b>Effective Date</b>	<b>Expiration Date</b>	<b>Hourly Rate</b>	<b>Fringe Benefits</b>	<b>Total</b>
Operators (Highway, Class 07/B - See Notes)	5/1/2025		\$50.37	\$33.97	\$84.34
Operators (Highway, Class 07/B - See Notes)	5/1/2026		\$51.84	\$34.90	\$86.74
Painters Class 2 (see notes)	5/1/2023		\$33.99	\$23.20	\$57.19
Painters Class 3 (see notes)	5/1/2023		\$40.09	\$23.20	\$63.29
Piledrivers	5/1/2023		\$35.32	\$19.09	\$54.41
Piledrivers	5/1/2024		\$36.12	\$19.79	\$55.91
Piledrivers	5/1/2025		\$36.87	\$20.49	\$57.36
Piledrivers	5/1/2026		\$37.63	\$21.18	\$58.81
Steamfitters (Heavy and Highway - Gas Distribution)	5/1/2022		\$48.43	\$40.28	\$88.71
Steamfitters (Heavy and Highway - Gas Distribution)	5/1/2023		\$50.53	\$41.68	\$92.21
Steamfitters (Heavy and Highway - Gas Distribution)	3/4/2024		\$50.53	\$41.83	\$92.36
Truckdriver class 1(see notes)	5/1/2021		\$37.72	\$0.00	\$37.72
Truckdriver class 2 (see notes)	5/1/2021		\$37.79	\$0.00	\$37.79
Truckdriver class 3 (see notes)	5/1/2021		\$38.28	\$0.00	\$38.28

## APPENDIX "C"

### ACT NO. 45-1998 (72 P.S. § 7201 ET SEQ.)

---

---

(pp) "Building machinery and equipment." Generation equipment, storage equipment, conditioning equipment, distribution equipment and termination equipment, which shall be limited to the following:

(1) air conditioning limited to heating, cooling, purification, humidification, dehumidification and ventilation;

(2) electrical;

(3) plumbing;

(4) communications limited to voice, video, data, sound, master clock and noise abatement;

(5) alarms limited to fire, security and detection;

(6) control system limited to energy management, traffic and parking lot and building access;

(7) medical system limited to diagnosis and treatment equipment, medical gas, nurse call and doctor paging;

(8) laboratory system;

(9) cathodic protection system; or

(10) furniture, cabinetry and kitchen equipment.

The term shall include boilers, chillers, air cleaners, humidifiers, fans, switchgear, pumps, telephones, speakers, horns, motion detectors, dampers, actuators, grills, registers, traffic signals, sensors, card access devices, guardrails and medical devices, floor troughs and grates and laundry equipment, together with integral coverings and enclosures, whether or not the item constitutes a

---

---

## APPENDIX “C”

### ACT NO. 45-1998 (72 P.S. § 7201 ET SEQ.)

---

fixture or is otherwise affixed to the real estate whether or not damage would be done to the item or its surroundings upon removal or whether or not the item is physically located within a real estate structure. The term “building machinery and equipment” shall not include guardrail posts, pipes, fittings, pipe supports and hangers, valves, underground tanks, wire, conduit, receptacle and junction boxes, insulation, ductwork and coverings thereof.



**WORKER PROTECTION AND INVESTMENT CERTIFICATION FORM**

A. Pursuant to Executive Order 2021-06, *Worker Protection and Investment* (October 21, 2021), the Commonwealth is responsible for ensuring that every worker in Pennsylvania has a safe and healthy work environment and the protections afforded them through labor laws. To that end, contractors and grantees of the Commonwealth must certify that they are in compliance with Pennsylvania’s Unemployment Compensation Law, Workers’ Compensation Law, and all applicable Pennsylvania state labor and workforce safety laws including, but not limited to:

1. Construction Workplace Misclassification Act
2. Employment of Minors Child Labor Act
3. Minimum Wage Act
4. Prevailing Wage Act
5. Equal Pay Law
6. Employer to Pay Employment Medical Examination Fee Act
7. Seasonal Farm Labor Act
8. Wage Payment and Collection Law
9. Industrial Homework Law
10. Construction Industry Employee Verification Act
11. Act 102: Prohibition on Excessive Overtime in Healthcare
12. Apprenticeship and Training Act
13. Inspection of Employment Records Law

B. Pennsylvania law establishes penalties for providing false certifications, including contract termination; and three-year ineligibility to bid on contracts under 62 Pa. C.S. § 531 (Debarment or suspension).

**CERTIFICATION**

I, the official named below, certify I am duly authorized to execute this certification on behalf of the contractor/grantee identified below, and certify that the contractor/grantee identified below is compliant with applicable Pennsylvania state labor and workplace safety laws, including, but not limited to, those listed in Paragraph A, above. I understand that I must report any change in the contractor/grantee’s compliance status to the Purchasing Agency immediately. I further confirm and understand that this Certification is subject to the provisions and penalties of 18 Pa. C.S. § 4904 (Unsworn falsification to authorities).

<i>Signature</i>	<i>Date</i>
<i>Name (Printed)</i>	
<i>Title of Certifying Official (Printed)</i>	
<i>Contractor/Grantee Name (Printed)</i>	

# APPENDIX E - HOW TO JOIN A PURCHASING TEAMS MEETING

**Teams works best in Edge or Chrome. It does not work in Internet Explorer.**

## The Meeting

- Step # 1. Go to the Purchasing ITB and RFP page on the County website at <https://www.berkspa.gov/Dept/Purchasing/Pages/ITBRFP.aspx>
- Step # 2. The Teams Live Event links for the Pre-Bid/Pre-Proposal, as well as the Bid/Proposal Opening will be posted with each specific Invitation to Bid (ITB) and Request for Proposal (RFP).
- Step # 3. Click on the meeting link associated with the ITB or RFP you are interested in for the appropriate event.
- Step # 4. Click Watch on the web instead.

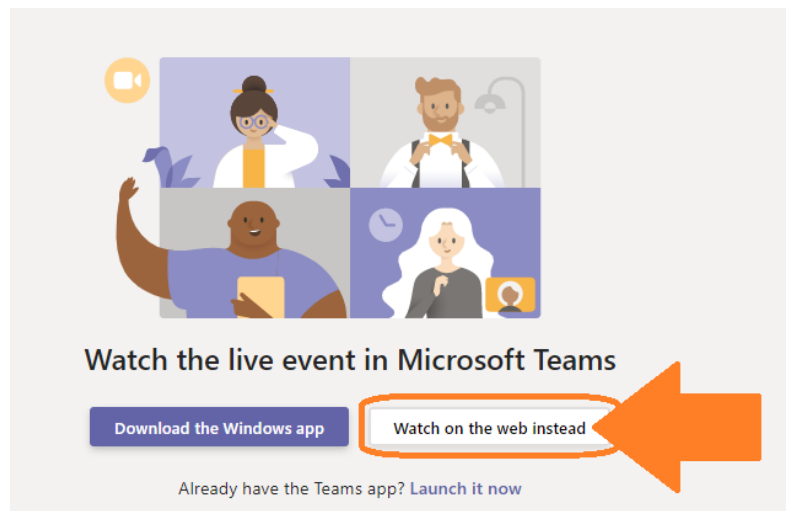

- Step # 5. You will be prompted to download the Teams app, Open in web browser (Edge or Chrome) or Launch the Teams app if you already have it. You can select Join on the web instead and join as a guest. If you have used Teams in the past, launch the app and use a verified account.



# APPENDIX E - HOW TO JOIN A PURCHASING TEAMS MEETING

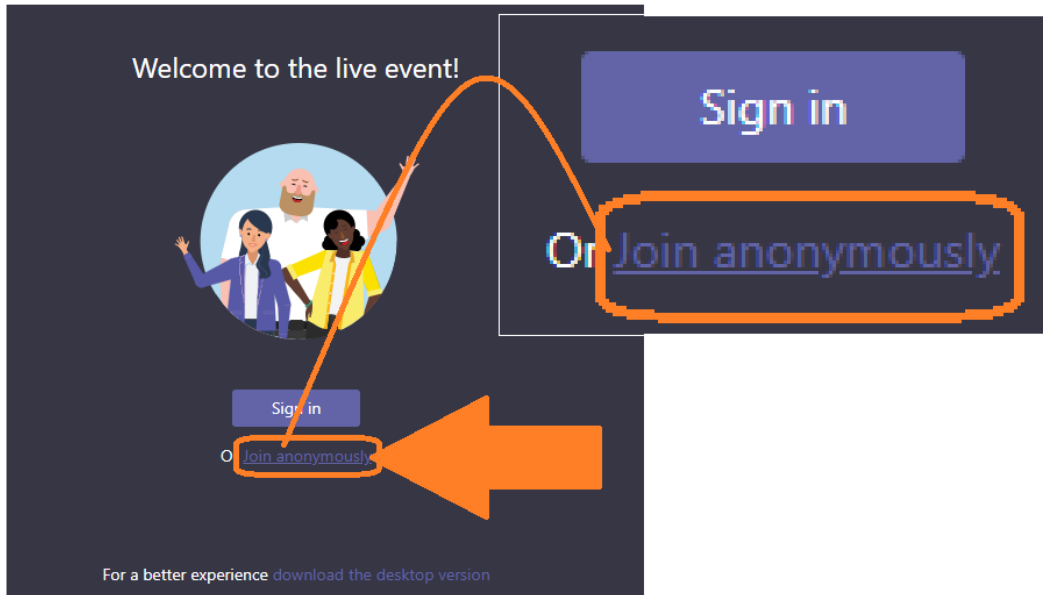

# APPENDIX E - HOW TO JOIN A PURCHASING TEAMS MEETING

- Step # 6. You will join the meeting in the “Lobby” until you are admitted by County staff.
- Step # 7. All Public participants join the meeting muted with cameras off. County staff will change your participation status at which point you can control your camera and microphone.
- Step # 8. Please add your name and company name to the Chat when you are admitted to the meeting. (This is only required for pre-bid/pre-proposal events.)
- Step # 9. You can use the Chat, “Raise Your Hand” feature or unmute and ask your questions real-time. Please keep your questions germane to the ITB/RFP being reviewed.
- Step # 10. Close the application or web browser window to leave the meeting.

End of process